

Office Doctor Discount Office Furniture

www.OfficeDr.com 856-368-9085

Groupe Lacasse Half Price Sale On Now

Take Half Off the List Prices in this PDF

Call 856-368-9085 Now

Free Layout & Design Service

Paradigm Panel Systems



LACASSE

Office Furniture Solutions



PARADIGM Panel System > Price Book > USA > February 2025



OFFICE
FURNITURE
SOLUTIONS

TABLE OF CONTENTS

SPECIFICATIONS 3

PARADIGM PANEL SYSTEM 3

GENERAL INFORMATION 3

PANELS AND COMPONENTS 4-8

ELECTRIFICATION AND CABLE MANAGEMENT 9-11

LAMINATE GALLERY PANELS 12

WORK SURFACES 12-13

SUPPORTS AND BASES 13-14

METAL STORAGE FURNITURE 15

LAMINATE STORAGE FURNITURE 15-16

PARADIGM PRICE LIST 17

MONOLITHIC PANELS 17

SEGMENTED PANELS 19

 1 GLASS UPPER SEGMENT 19

 1 FABRIC UPPER SEGMENT 21

 1 LAMINATE UPPER SEGMENT 22

 FABRIC AND GLASS UPPER SEGMENTS 23

 2 FABRIC UPPER SEGMENTS 23

LAMINATE GALLERY PANELS 24

SCREENS AND STACKABLE PANELS 26

PANEL COMPONENTS 27

ELECTRICAL COMPONENTS – 3-CIRCUIT SYSTEM 29

ELECTRICAL COMPONENTS – 4-CIRCUIT SYSTEM 29

ELECTRICAL ACCESSORIES 30

WORK SURFACES WITH CABLE DROP 31

STANDARD WORK SURFACES 32

WORK SURFACE SUPPORTS 34

WORK SURFACE BASES 34

METAL STORAGE FURNITURE 35

LAMINATE STORAGE FURNITURE 36

ACCESSORIES 38



Paradigm Panel System had achieved GREENGUARD Certification.

GREENGUARD Certified products are certified to GREENGUARD standards for low chemical emissions into indoor air during product usage. For more information, visit ul.com/gg.

SPECIFICATIONS

PARADIGM PANEL SYSTEM

PARADIGM is an office furniture system that uses panels to help create workstations. Its well-thought-out, sleek components make it possible to create as wide a variety of stimulating work environments as one can imagine. Robust and modular, the system is easily reconfigurable to suit the evolving needs of the business and its users. PARADIGM's finishes can be selected to create a harmonious look with the numerous other collections of office furniture and metal storage units offered by Groupe Lacasse.

Here is how to specify a work environment

1. Divide the open area into workstations using the panels and their components.
2. Determine each user's electrical requirements.
3. Specify the surfaces and supports/legs based on the desired ergonomics of each workstation.
4. Specify the storage units according to user needs.
5. Complete the workstations with accessories.
6. Add chairs or upholstered furniture from our United Chair and Arold brands.

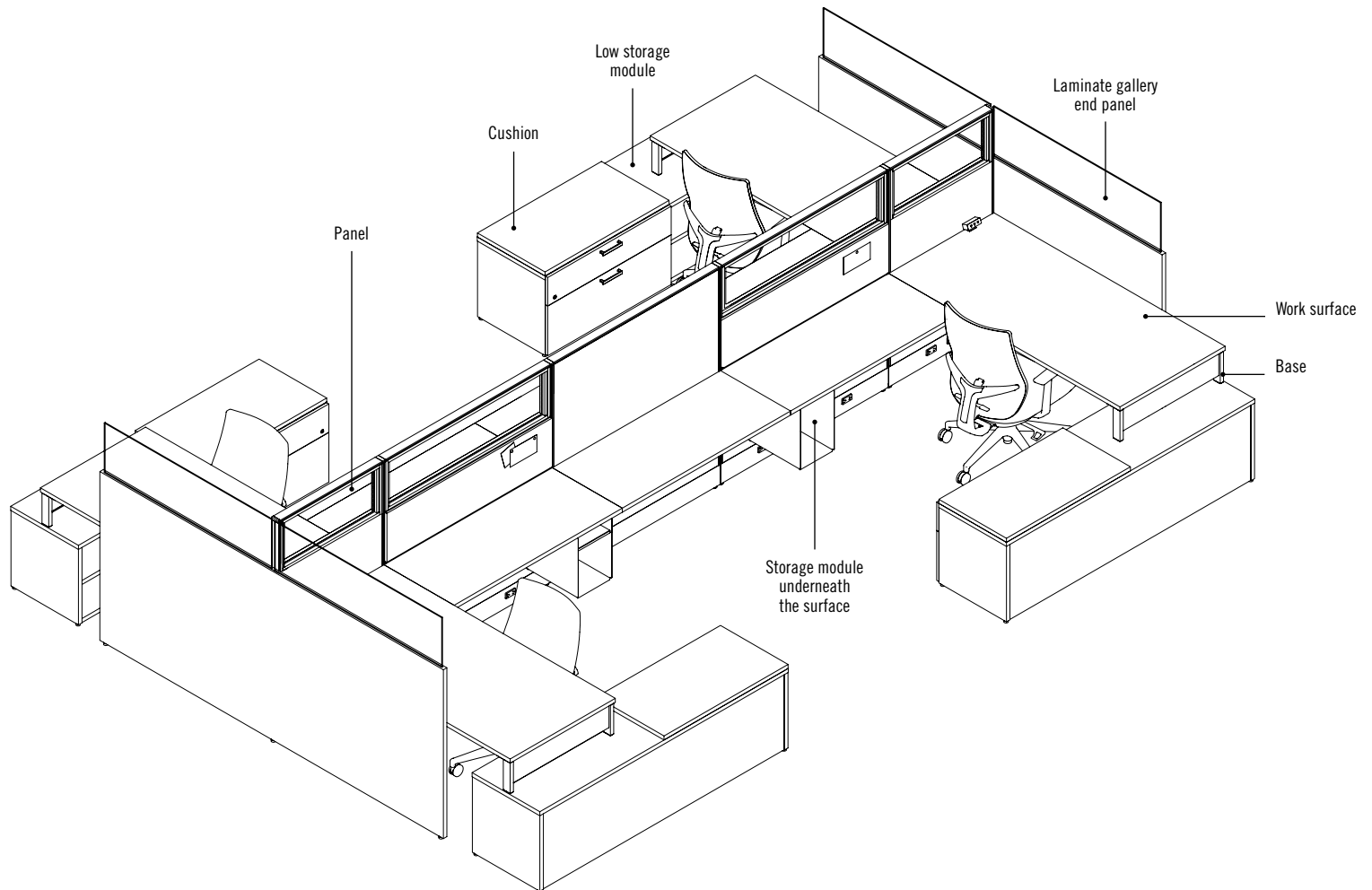

GENERAL INFORMATION

Ratings

Fire rating

- Class A fire rating.

BIFMA rating

- PARADIGM meets or exceeds the standards set by ANSI/BIFMA.

Electrical rating

- Electrical components are UL183 listed and certified for use in Canada and the United States.
- Electrical components are cUL listed.
- They meet the requirements of articles 604 and 605 of the National Electric Code (NEC/CSA /CE).

PANELS AND COMPONENTS

Panel construction – external view

- Imperial and metric dimensions are exact.
- Panels with a fabric finish can be used as tackboards.

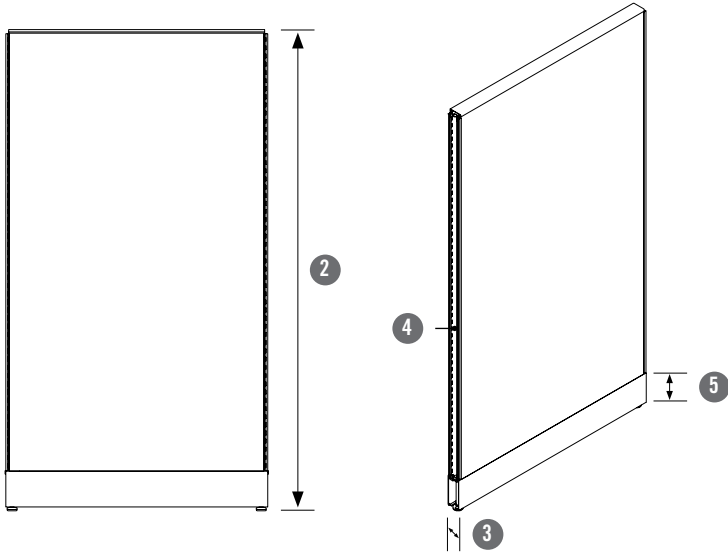

- 1 Panel width is measured from center line to center line of the in-line junction connectors. Panels are available in 24" (610 mm), 30" (762 mm), 36" (914 mm), 42" (1067 mm), 48" (1219 mm) and 60" (1524 mm) widths.
- 2 Panel height is measured from the leveler (minimum position) to the top trim. A leveler can make an adjustment of up to 2" (51 mm). Panels are available in 29 $\frac{1}{8}$ " (758 mm), 42 $\frac{1}{4}$ " (1072 mm), 48 $\frac{3}{8}$ " (1229 mm), 54 $\frac{1}{2}$ " (1386 mm) and 66 $\frac{7}{8}$ " (1700 mm) heights.
- 3 Panel thickness is 2" (51 mm).
- 4 Panels are equipped with side rails to accept work surfaces, storage modules and accessories.
- 5 The raceway is 5" (125 mm) high.

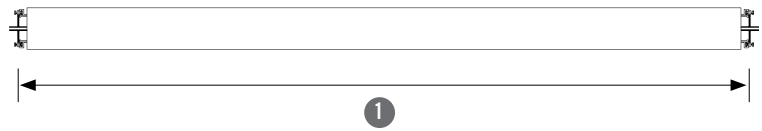

Panel construction – internal view

- Raceway covers, side rails, trims and top caps are made of painted aluminum.
- $\frac{1}{4}$ " (6 mm) tempered glass with clear or frosted finish.

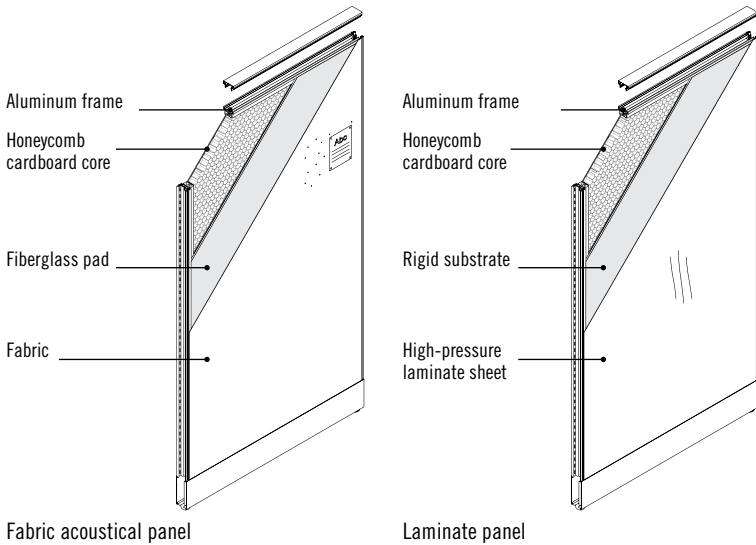

What a panel includes

Example: KPMA-6636-3P

#	Components	Qty
1	Side rails	2
2	Top trim	1
3	Junction cap	0.6*
4	Raceway covers	2
5	Glides	2
6	Alignment systems	2
7	In-line junction connector	1.6*
8	Electrical system**	1
9	Electrical connector**	0.6*

- * A ratio has been established to ensure that each order comes with a sufficient number of components to allow an optimal configuration while avoiding wastefulness.
- ** Components included with a powered panel.

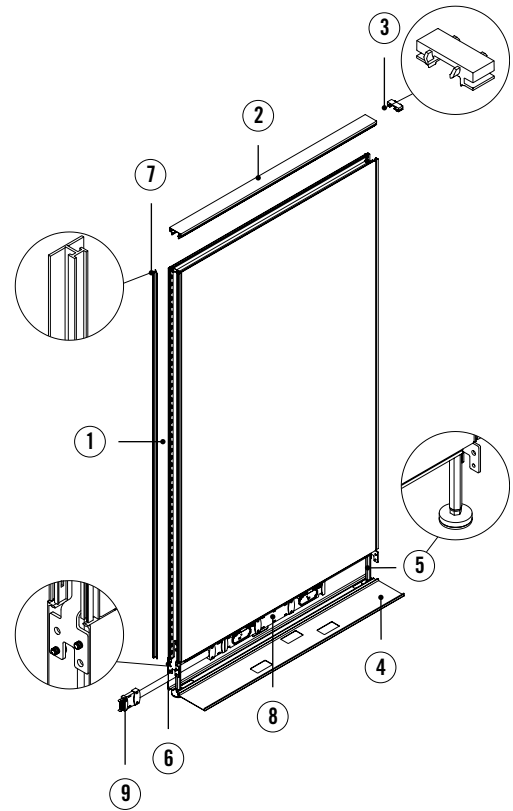

PANELS AND COMPONENTS (cont'd)

Panel dimensional range

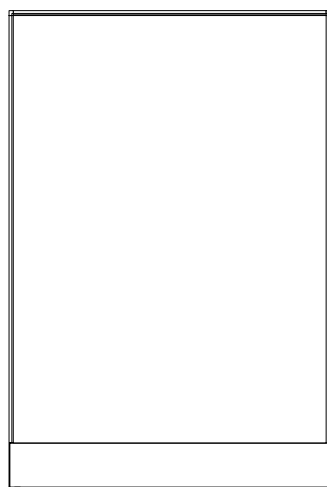
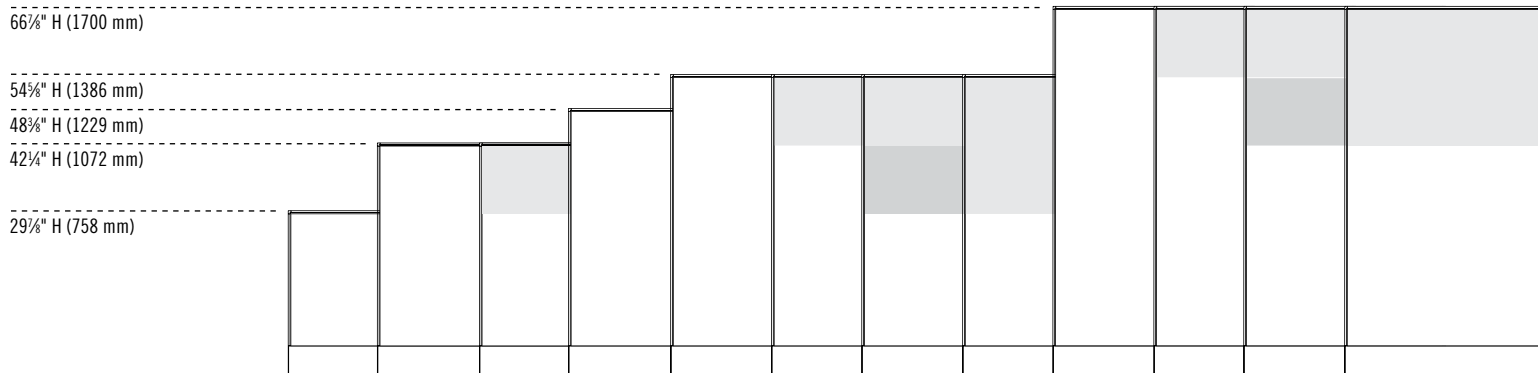

Monolithic panel

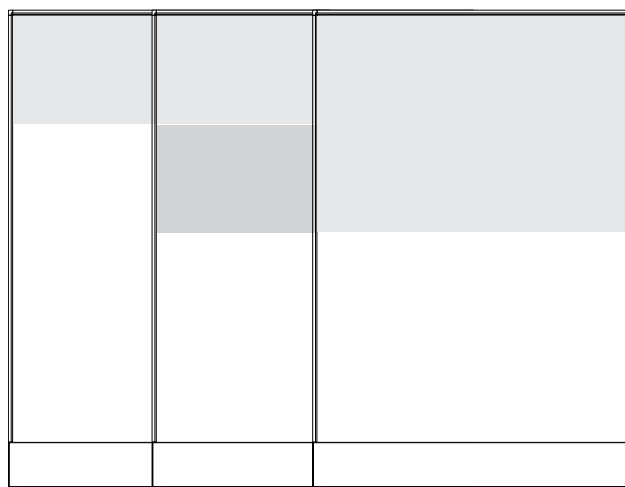

Segmented panels



Available finishes:
Fabric, laminate or glass
Upper segment 12³/₈" (314 mm) or 24³/₄" (628 mm)



Available finishes:
Fabric or laminate
Middle segment 12³/₈" (314 mm)



Available finishes:
Fabric, laminate or combined
Base

Some combinations are not available as a standard order. Contact the Special Orders department at special@groupelacasse.com.

- Segmented panels are factory-assembled.
- Different finishes can be applied on each side of a panel. Refer to the codification table (see page 17).

- A segmented panel can have only one glass segment, always positioned on the upper portion.
- The glass segment cannot support a storage unit or an accessory.

Stackable panels

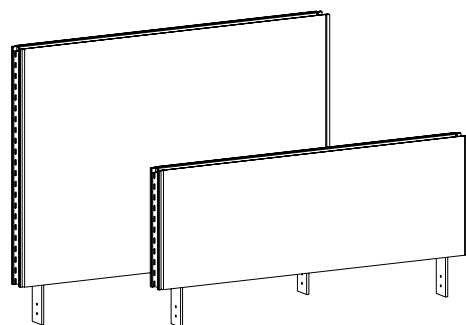

- Stackable panels can be used to increase panel height if necessary during a reconfiguration.
- A stackable panel can be installed over a monolithic* or segmented panel.
- A stackable panel cannot be installed over a glass segmented panel.
- Total panel height, including stackable panels, cannot exceed 66⁷/₈" (1700 mm).
- A maximum of 2 stackable panels can be used. Their combined height cannot exceed the height of the base panel.

- A glass stackable panel cannot accept any other stackable component.
- A stackable panel cannot support any storage unit or accessory.

* 48" (1219 mm) monolithic panels can accept stackable panels. However, the height of the end-of-run trim and the junction kits must be cut at the installation job site.



Available finishes:
Fabric, laminate, glass or combined

PANELS AND COMPONENTS (cont'd)

Glass privacy screens for panels

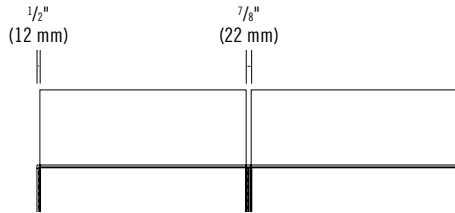
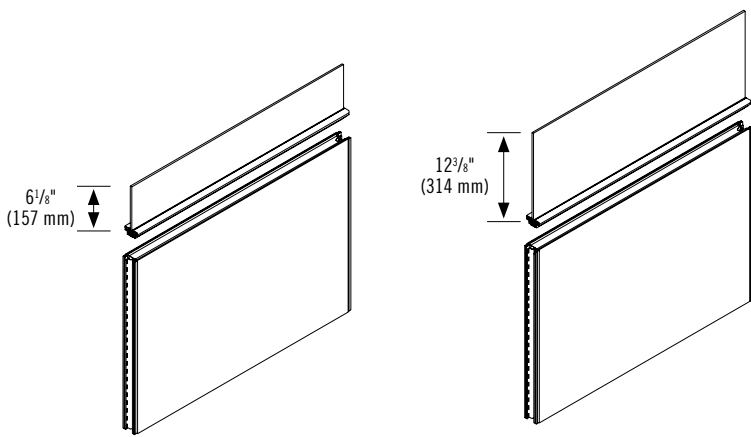
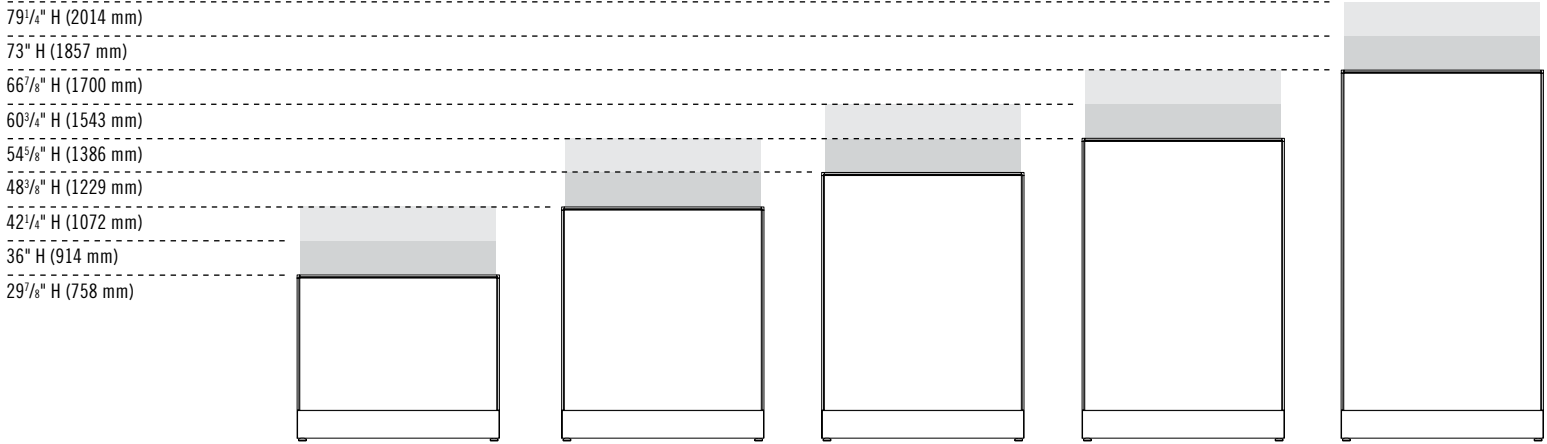

Optional alignment hardware is available to align the top of the glass privacy screens in a straight line application.

- Glass privacy screens for panels are sold with top trim.
- Available heights are 6 1/8" (157 mm) and 12 3/8" (314 mm) and enable a visual alignment with the panels.
- The screens can be installed on monolithic, segmented or stackable panels.
- A privacy screen can be installed on a panel up to 66 7/8" (1700 mm) high to reach a total height of 79 1/4" (2014 mm).
- Tempered glass privacy screens are available with clear or frosted glass 1/4" (6 mm) thick.
- Glass privacy screens cannot be installed on top of glass segments or glass stackable panels.

Junction connector applications

- Junction connectors are used to connect panels of identical or variable height.
- Junction connectors are black and are used as continuous vertical barriers between panels in order to block light.
- In-line junction connectors are included with the panels (refer to pages 17 to 24).
- 90-degree junction connectors are included in junction kits (refer to pages 27 and 28).

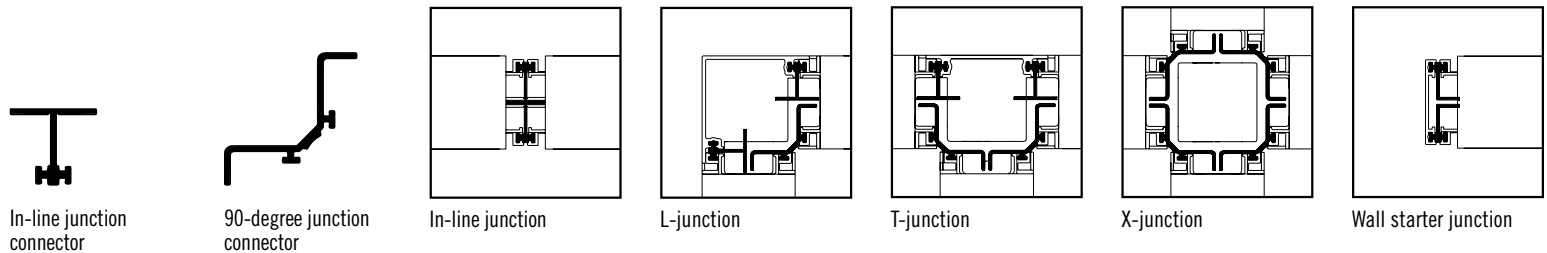

Wall starter attachment

- The wall starter is fastened in-line on the side rail using junction connectors. The footprint is thereby increased by 5/16" (8 mm).

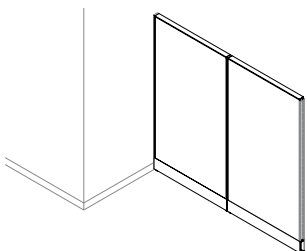

PANELS AND COMPONENTS (cont'd)

End-of-run trim

- To give the panel a finished look, it is necessary to specify an end-of-run trim.

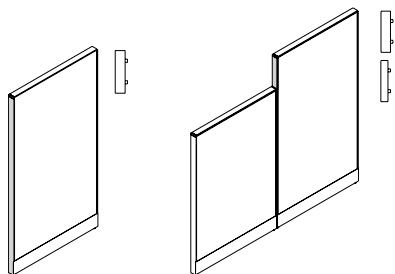

End-of-run trim
Variable height end-of-run trim

Full-height junction kits

- For standard configurations, junction kits have been designed to facilitate specification. These kits include all the components necessary to achieve the arrangements shown below.

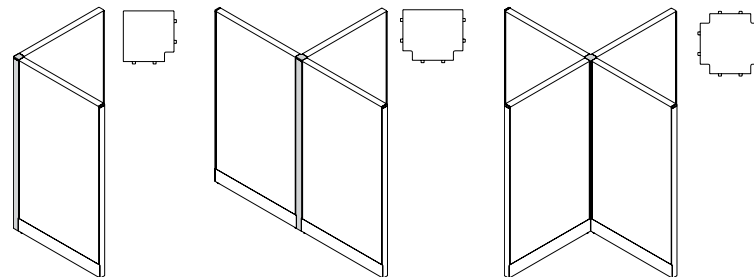

L-junction kit
T-junction kit
X-junction kit

Variable-height junction kits

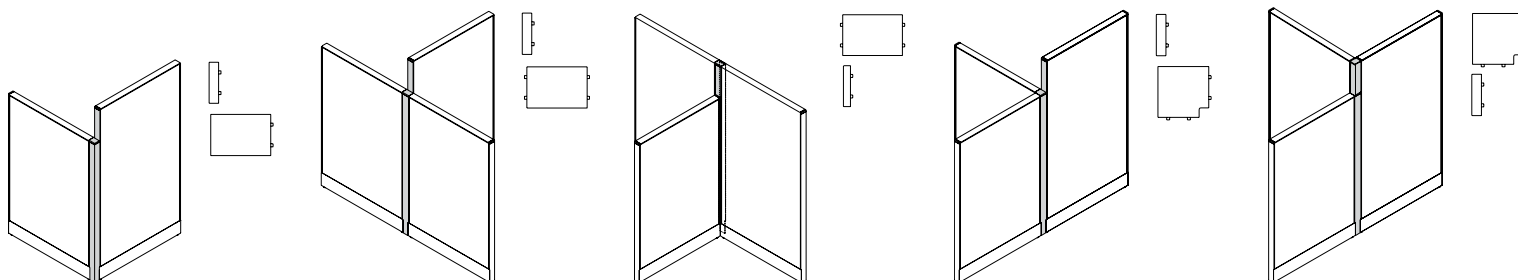

L-junction kit
T-junction kit -Type A
T-junction kit -Type B
T-junction kit -Type C
T-junction kit -Type D

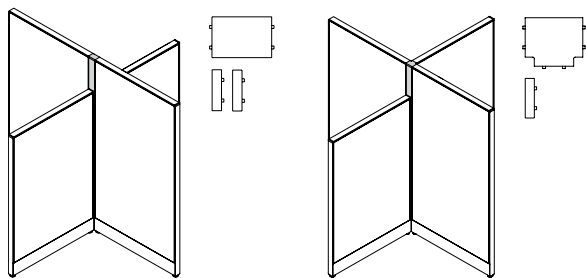

X-junction kit -Type A
T-junction kit -Type B

Caps required for center-mounted hutches and transaction countertops

- A selection of caps is available to achieve a continuous, elegant look. Certain configurations with center-mounted hutches or transaction countertops will require ordering additional top caps with the appropriate junction kit. The arrangements below may also be achieved with transaction countertops.

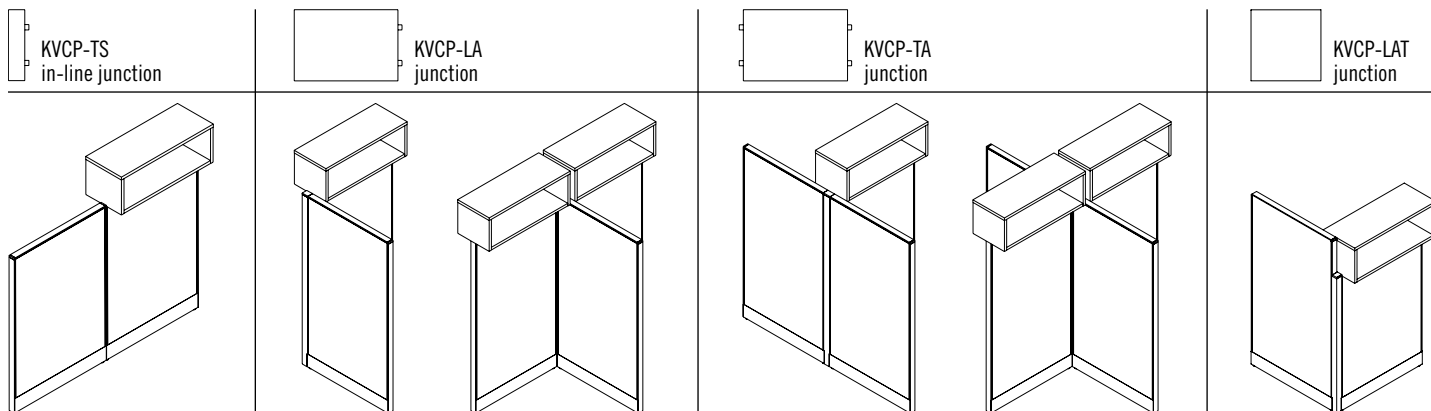

PANELS AND COMPONENTS (cont'd)

Raceway covers

- 2 raceway covers are included with a panel.
- Raceway covers can be ordered separately in order to create personalized configurations.

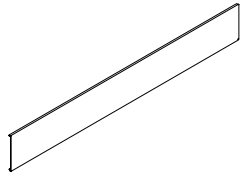

No cut-outs (N)

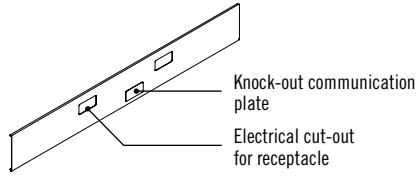

With cut-outs (P)

- The communication plate can be knocked out and is slightly off-center to enable back-to-back use of communication plates.
- Covers for electrical and communication cut-outs are available for unused cut-outs.

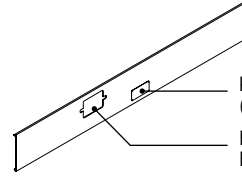

With Chicago-type cut-outs (H)

Positioning of type P cut-outs

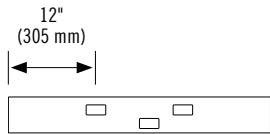

12" (305 mm)
36, 42, 48, 60" (914, 1067, 1219, 1524 mm):
2 cut-outs for receptacle and 1 knock-out communication plate

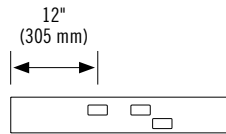

12" (305 mm)
30" (762 mm): 2 cut-outs for receptacles and 1 knock-out communication plate

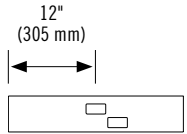

12" (305 mm)
24" (610 mm): 1 cut-out for receptacle and 1 knock-out communication plate

Positioning of type H cut-outs

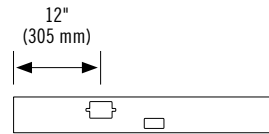

12" (305 mm)
36, 42, 48, 60" (914, 1067, 1219, 1524 mm):
1 cut-out for junction box and 1 knock-out communication plate

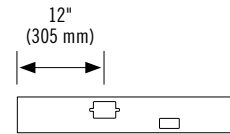

12" (305 mm)
30" (762 mm): 1 cut-out for junction box and 1 knock-out communication plate

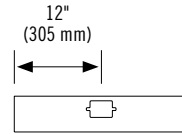

12" (305 mm)
24" (610 mm): 1 cut-out for junction box

Dimensions of cut-outs

Cut-out for receptacle and communication plate

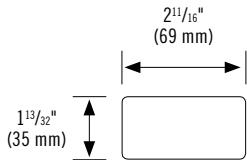

Dimensions of type H cut-outs

Cut-out for junction box

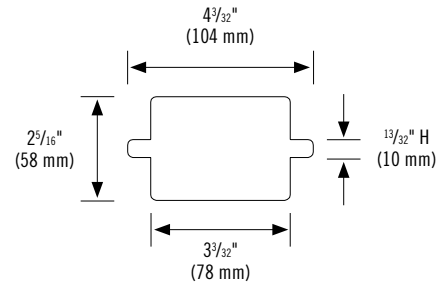

ELECTRIFICATION AND CABLE MANAGEMENT

Here are the 4 steps in order to provide electric power to a workstation

STEP 1:
Define the electrical system required as a function of needs and the number of users.

STEP 2:
Determine the power infeed.

STEP 3:
Specify the number of electrical receptacles and connectors.

STEP 4:
Complete a workstation set-up with accessories.

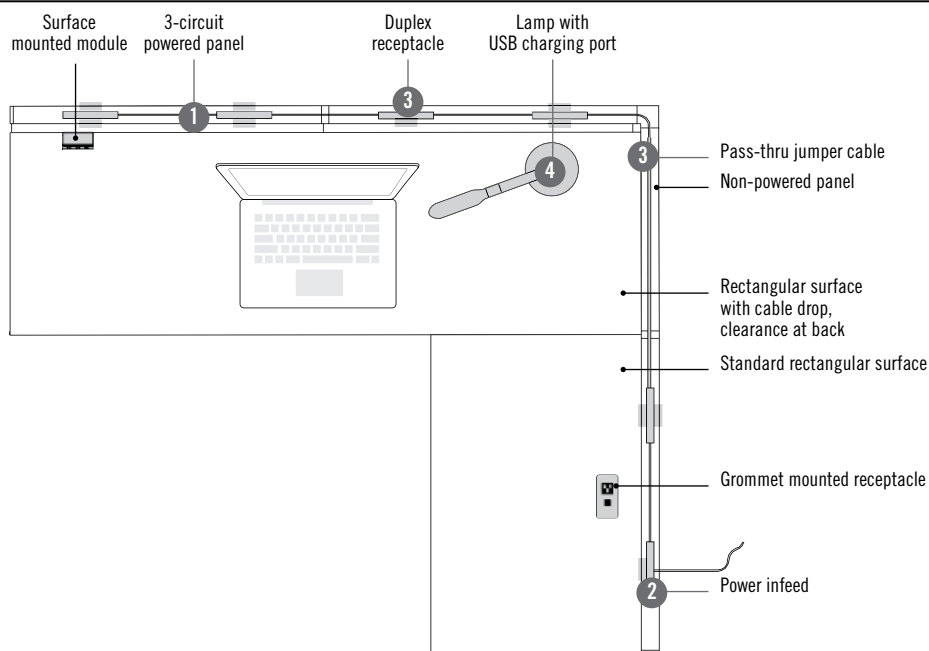

1. Define the electrical system required, according to needs and the number of users.

The choice of electrical system is based on the number of electrical and electronic devices to be plugged in at each workstation. An electrician is qualified to determine the power (amperage) used simultaneously and to recommend the best electrical system and the number of power sources required. The two electrical systems available connect only to 120 Volt / 60 Hertz power sources. Note: If the devices are in continuous use for more than 3 hours, as computers, lamps and screens generally are, it is recommended that the circuits be used at only 80% of their capacity.

3-circuit, 5-wire electrical system

The 3 circuits are common and share the same neutral wire and the same ground wire.

This modular system includes:

- 3 hot wires in 12-gauge copper.
- 1 common neutral wire in 10-gauge copper.
- 1 common ground wire in 12-gauge copper.

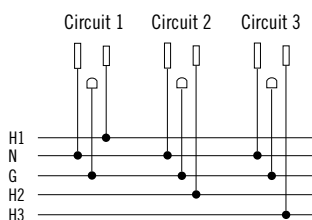

Compatible with single-phase and three-phase currents, respectively 240 / 120V, 208 / 120V.

Based on the Canadian Electrical Code (CE Code) / National Electric Code (NEC):

United States: 20-amp circuit.

- 13 receptacles and a maximum of 15 amps per circuit, for a total of 39 receptacles per power source (total capacity of 60 Amps).

Canada: 15-amp circuit.

- Maximum of 10 receptacles per circuit, for a total of 30 receptacles per power source (total capacity of 45 Amps).

If necessary or based on your needs, a 1+1 system is also available. Contact Customer Service for full details.

Important:

The electrical components for a 3-circuit, 5-wire system differ from those for a 4-circuit, 8-wire system. These components are not interchangeable from one system to the other. Accordingly, special attention is required during specification. Take note of whether the product code includes the digit '3' or '4'.

4-circuit, 8-wire electrical system

The 4th circuit is isolated and dedicated. It has its own neutral wire and ground wire.

This modular system includes:

- 4 hot wires in 12-gauge copper.
- 1 common neutral wire in 10-gauge copper.
- 1 dedicated neutral wire in 12-gauge copper.
- 2 ground wires in 12-gauge copper.

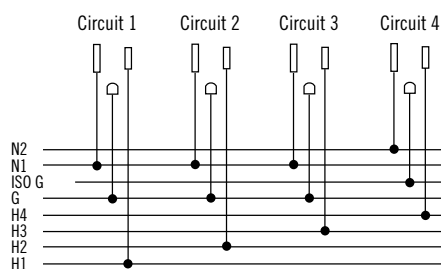

Compatible with single-phase and triple-phase currents, respectively 240 / 120V, 208 / 120V.

Based on the Canadian Electrical Code (CE Code) / National Electric Code (NEC):

United States: 20-amp circuit.

- 13 receptacles and a maximum of 15 amps per circuit, for a total of 52 receptacles per power source (total capacity of 80 Amps).

Canada: 15-amp circuit.

- Maximum of 10 receptacles per circuit, for a total of 40 receptacles per power source (total capacity of 60 Amps).

If necessary or based on your needs, a 2+2 system is also available. Contact Customer Service for full details.

ELECTRIFICATION AND CABLE MANAGEMENT (cont'd)

2. Determine the power infeed.

Floor feed

- 3 types of base feed are available.
- The infeed plugs into the receptacle location.
 - The plug protrudes by 1½" (38 mm).

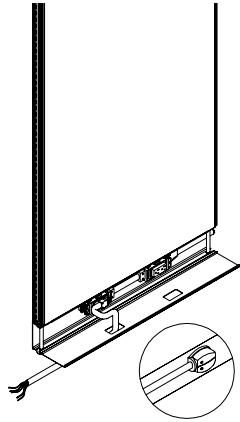

Hardwire base feed

- Plugs into the receptacle location.
- Equipped with a 72" (1829 mm) liquid tight conduit.

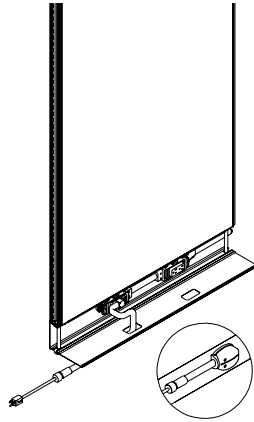

20-amp plug-in base feed

- Plugs into a receptacle.
- Equipped with a 24" (610 mm) cord.
- Powers circuit No. 1 only
- UL Recognized, cUL Approved.

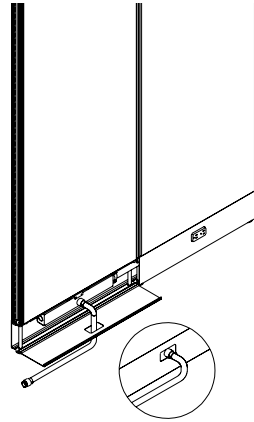

Concealed base feed

- The installation of a concealed base feed requires a non-powered panel.
- Equipped with a 72" (1829 mm) flexible metal conduit.
- Meets the standards of the New York City Building Code.
- A Type P cover can be ordered.

Ceiling feed

- The pole with electrification is equipped with a 168" (4267 mm) flexible metal conduit suitable for installation with ceilings 144" (3657 mm) high.
- The 144" (3657 mm) tall pole is used at a panel end.
- The 114" (2895 mm) tall pole is used in an LTX configuration.
- For a configuration at a panel end, the footprint increases by 2" (51 mm).
- The pole makes it possible to separate the electrical wires from the communication cables.
- The pole comes with mounting hardware for drop ceilings, for a safe installation.

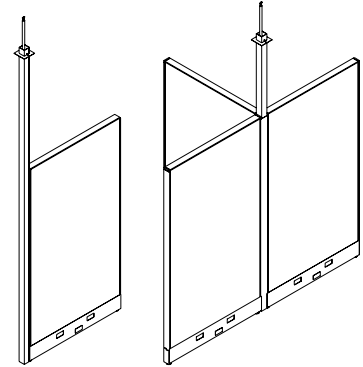
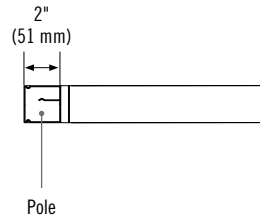

3. Specify the number of electrical receptacles and connectors.

Connectors for electrified junctions

Each powered panel comes with a power connector that enables in-line panel-to-panel connections.

Powered panels separated by a junction kit or a laminate gallery end panel require additional connectors.

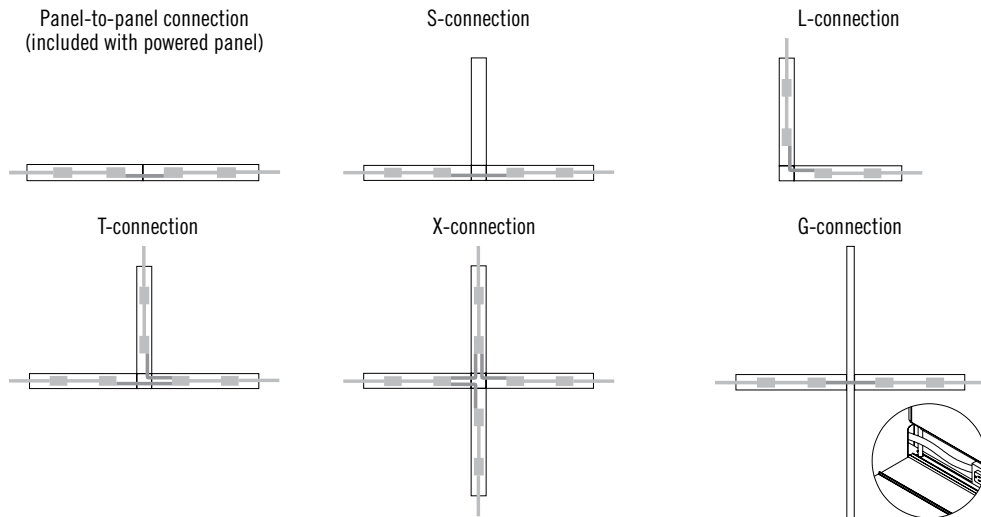

Pass-thru jumper cables for non-powered panels

When planning workstations requiring the passage of power cables through one or several non-powered panel(s), it is possible to order pass-thru jumper cables according to the electrical system chosen.



Duplex receptacles

- Each receptacle is comprised of 2 electric outlets.
- Receptacles connect to the electrical system in a tool-free installation.
- Receptacles are identified by circuit: 1 to 3, or 1 to 4, according to the electrical system chosen.
- The triangle indicates that the circuit is isolated and dedicated (4-circuit system only).
- If you are not sure what your needs are, we suggest ordering equal quantities of the receptacles for each of the circuits: C1-C2-C3-D4.

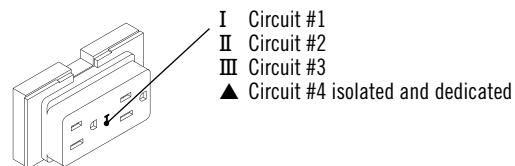

ELECTRIFICATION AND CABLE MANAGEMENT (cont'd)

4. Complete the workstation set-up with accessories.

Surface electrification

Receptacles for work surfaces are available in order to have more electrical access points.

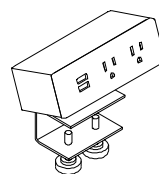
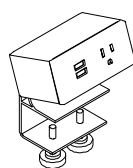
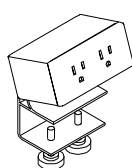

Installed at the same time as the work surface. Compatible with work surfaces with or without cable drop clearance.

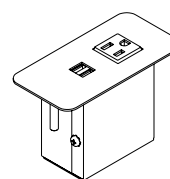

Installed in the location of a grommet.

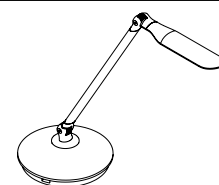

Office lamp with USB charging port.

Accessories for cable management

Cable and power management beneath the work surfaces can be done with various components:

Fastener for cable management (horizontal)

- Holds cables together beneath the work surface, for cable management.

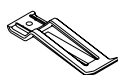

Vertical wire cover

- Enables cable management from the work surface to the floor.
- 2" (51 mm) diameter.
- With zipper.
- Black fabric.

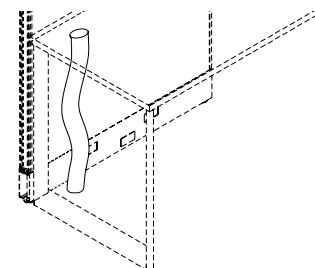

Cable capacity*

The pole and raceways have a cable capacity that varies with the cable category used.

Category 5e (cable with 0,20" (5 mm) diameter).

Category 6 (cable with 0,25" (6,35 mm) diameter).

Cable capacity with a 4-circuit system

Powered raceway

Powered pole

60% capacity		40% capacity	
Cat. 5e	Cat. 6	Cat. 5e	Cat. 6
26	18	18	12
44	28	29	18

Cable capacity with a 3-circuit system

Powered raceway

Powered pole

60% capacity		40% capacity	
Cat. 5e	Cat. 6	Cat. 5e	Cat. 6
34	21	23	14
44	28	29	18

Cable capacity with no electrical system

Non-powered raceway

Communication pole

60% capacity		40% capacity	
Cat. 5e	Cat. 6	Cat. 5e	Cat. 6
62	50	41	33
44	28	29	18

Non-powered raceway

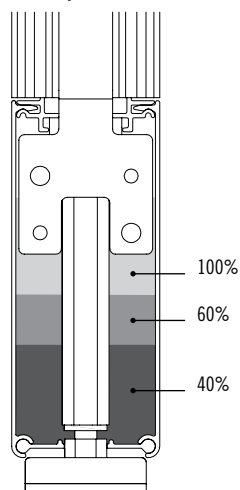

Communication pole

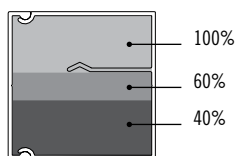

* For information purposes only. Actual cable capacity may vary according to the type of set-up and the electric modules used.

LAMINATE GALLERY PANELS

Glass privacy screens

54 $\frac{3}{8}$ " H (1386 mm)
 48 $\frac{3}{8}$ " H (1229 mm)
 42 $\frac{1}{4}$ " H (1072 mm)
 36" H (914 mm)
 29 $\frac{7}{8}$ " H (758 mm)

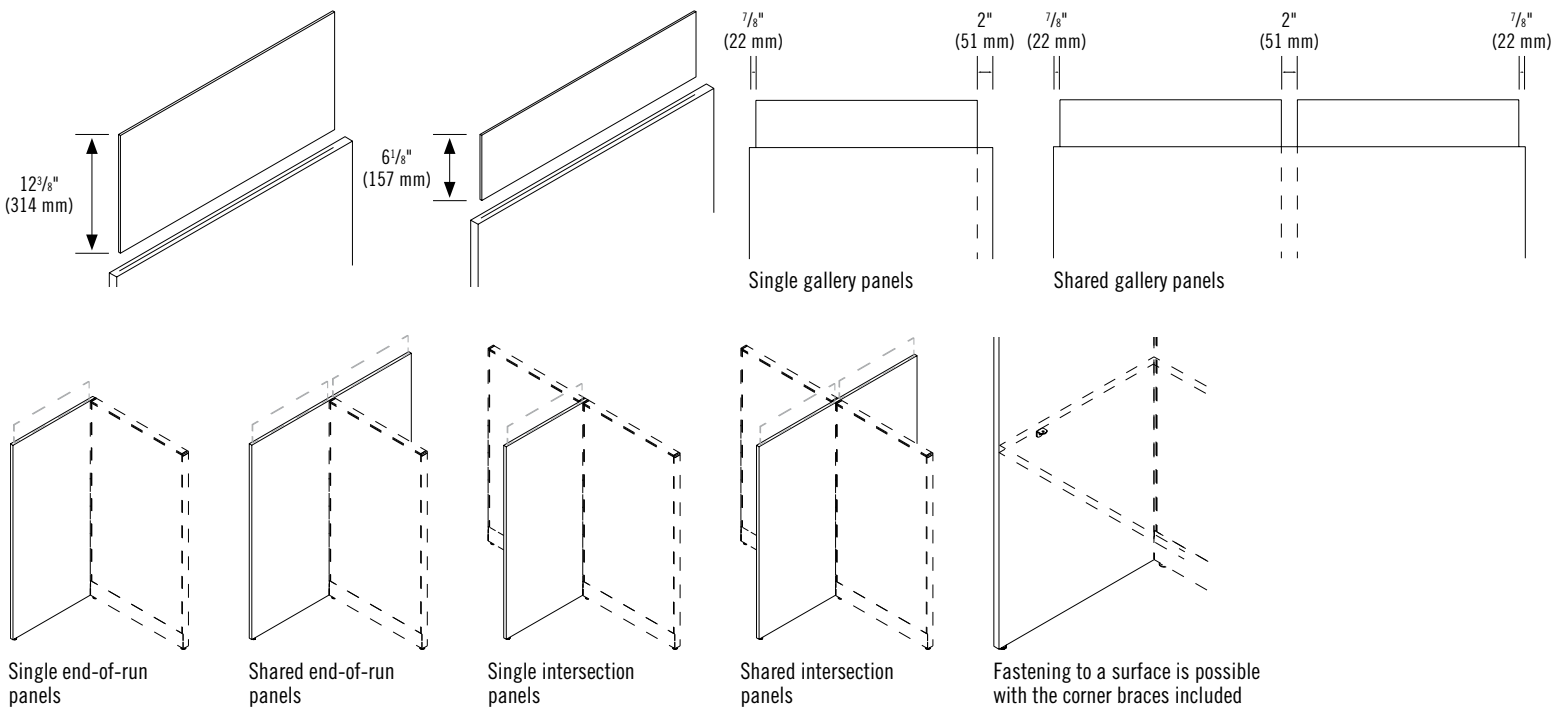

Characteristics of laminate gallery panels

- Gallery panels provide full or partial privacy when one is seated.
- They must be fastened to a monolithic or segmented panel of the same height or taller.
- A cut-out at the bottom of the laminate intersection panel makes it possible to pass power cables between two monolithic or segmented panels (refer to page 10).

- Gallery panel length includes 2" (51 mm) panel thickness.
- L-bracket included for fastening the front corner of a work surface to the gallery panel.
- Tempered glass privacy screens are available in clear or frosted glass 1/4" (6 mm) thick.

WORK SURFACES

General characteristics

- Work surfaces are made of particleboard panels finished on both sides, in mar-resistant thermofused laminate (45 lb/ft³) 1" (25 mm) thick, also known as "high-performance laminate."
- High-pressure laminate work surfaces are also available. Add 1/16" (1,5 mm) to the thickness of the work surface.
- All work surfaces are finished with ABS edgebanding in matching color.
- Work surfaces 23" (585 mm) in width or more can accept a keyboard tray.
- Monitor screen supports may be installed in a grommet location or on work surfaces that have a cable drop clearance.
- Work surfaces have metal-to-metal fittings so as to maintain product integrity during the installation or rearrangement of the cantilever supports.

Grommets and cable management

- Work surfaces may be ordered with or without grommets.
- Rectangular and corner work surfaces are also available with a 1" (25,5 mm) cable drop clearance.
- Grommets are positioned at various locations on the work surface (refer to illustration on next page).
- The plastic grommet is rectangular and silver colored.

WORK SURFACES (cont'd)

Without grommets

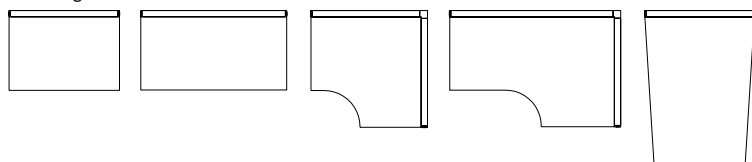

With grommets

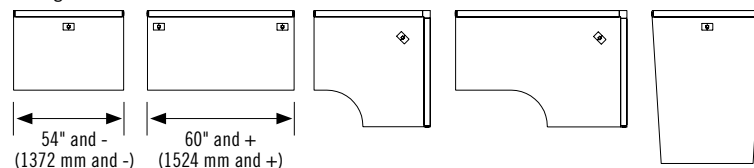

With cable drop clearance at back

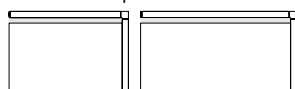

With cable drop clearance at back and on 1 side

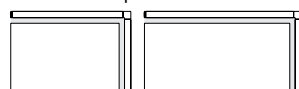

With cable drop clearance at both backs

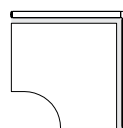

SUPPORTS AND BASES

Supports

- Supports are sold separately from work surfaces, with the exception of transaction countertops.
- Supports are coated with durable electrostatic paint.

Cantilever supports

- Left or right cantilever supports (sold as a pair) are fastened to the ends of a work surface.
- A third cantilever support, left or right, is required when the surface width exceeds 60" (1524 mm).
- They support work surfaces of all depths.
- They are compatible with work surfaces that have a cable drop clearance.
- Shared cantilever supports are installed between 2 work surfaces.
- They are made of 14-gauge steel and equipped with an anti-dislodgement device.

Corner or end brackets

- Corner or end brackets support the back of a corner work surface.
- They support the front of a work surface in order to stabilize a return panel.
- They support a rectangular or trapezoidal conference work surface whose width is identical to that of the panel.
- They support a 24" (610 mm) lower shelf of a suspended storage with drop-down door, when the lower shelf is installed on a panel of the same width.
- They support the back of a work surface when a fixed pedestal is installed.
- They are compatible with work surfaces that have a cable drop clearance.
- They are made of 14-gauge steel and equipped with an anti-dislodgement device.

Flat bracket

- Flat brackets make it possible to set up a conference work surface with another work surface.

Reinforcement bars

- A reinforcement bar is recommended for any work surface when the distance between 2 cantilevers is 48" to 60" (1219 to 1524 mm).
- A reinforcement bar is not a replacement for a support.
- The reinforcement bar supports the 24" (610 mm) lower shelf of a suspended storage with drop-down door when the lower shelf is installed on a panel with a different width.

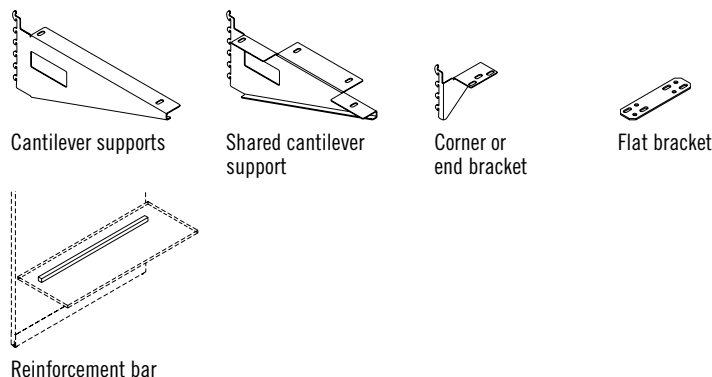

Configuration of brackets

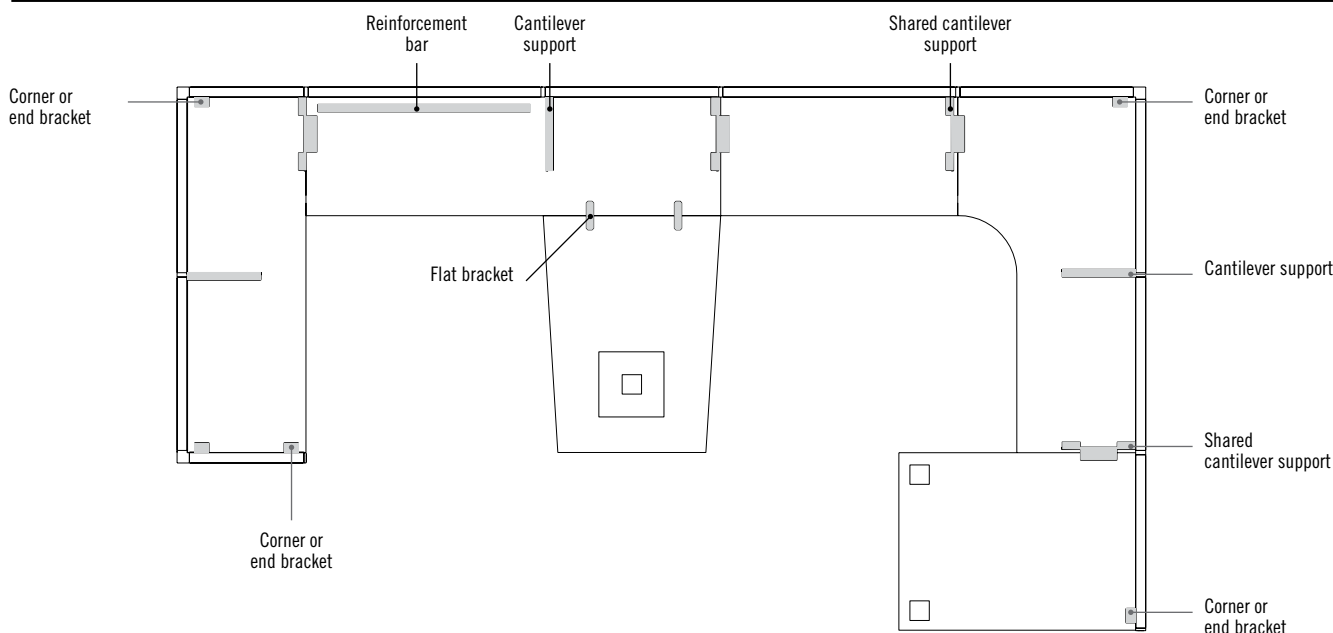

SUPPORTS AND BASES (cont'd)

End frame for panel

Different types of bases can be attached to a panel and are used to support a work surface at one end.

- 4 models available.
- P-metal and laminate bases allow a vertical adjustment of the panel of 1½" (38 mm).
- No adjustment is possible with the intermediate P-metal base used with a low storage unit.

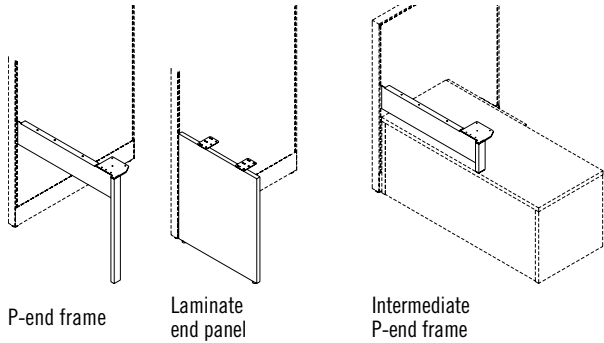

Ped-to-panel attachment filler

- Enables a full-height finish behind a modular metal pedestal.
- Available for surfaces 20" (508 mm) and 24" (610 mm) deep, according to the depth of the pedestal.

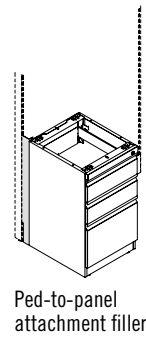

Leg/frame for surface

Different types of leg / frame make it possible to support work surfaces at their end.

- 5 models are available.
- A and O-metal frames allow a vertical adjustment of 1½" (38 mm).
- An I-leg allows a vertical adjustment of 1¼" (32 mm).
- An I-leg with a conference base allows a vertical adjustment of 1/8" (3 mm).
- No adjustment is possible with an intermediate A-metal leg used with a low storage unit.

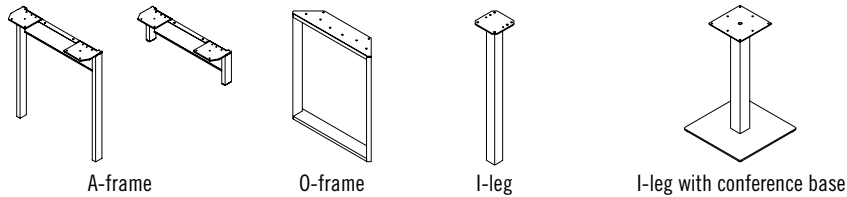

Configuration of supports

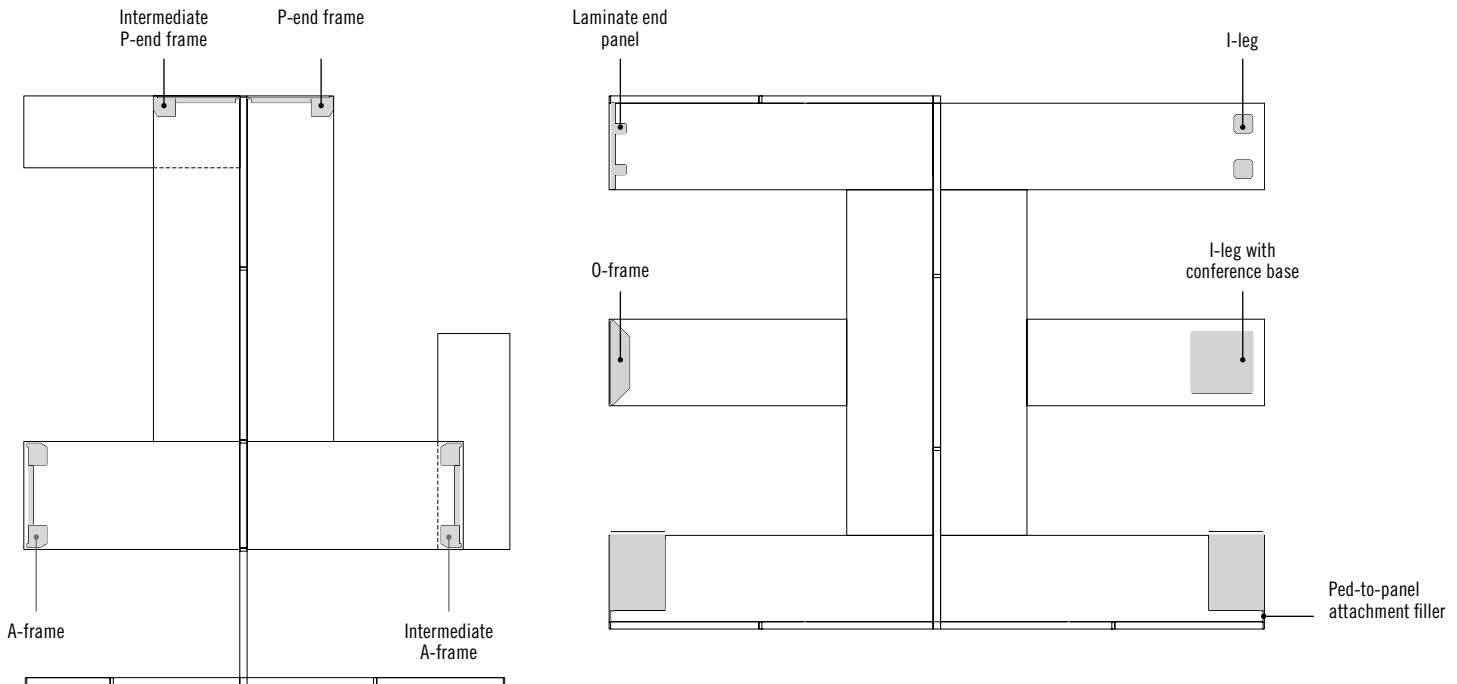

METAL STORAGE FURNITURE

Storage units

- A suspension bar is included in each file drawer.
- Metal front with full-width metal handles matching pedestal color.
- Optional laminate front with handles.
- Modular pedestals must be installed beneath a 29" (737 mm) work surface and combined with a corner or end support or a ped-to-panel attachment filler.
- Personal mobile storage units include a hidden drawer, an accessible compartment on the left or right or a file drawer.
- Cushions are available for the mobile pedestal and the personal mobile storage units.
- Metal storage furniture is equipped with levelers or casters and comes assembled and ready to use.
- The levelers installed on metal storage furniture allow a vertical adjustment of 1³/₄" (32 mm).

- All metal storage furniture is equipped with a standard lock and 2 keys per lock. All locks are easily changed at the installation job site. It is possible to change the cylinders and to install a single-key system. A master key and control key are also available. Contact Customer Service for full details.

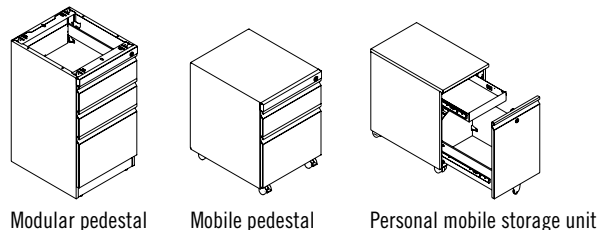

Modular pedestal Mobile pedestal Personal mobile storage unit

Hanging personal storage compartments

- Metal storage units can fit into one another.
- Laminate shelf available as an option.
- They must be installed beneath a work surface.
- Metal storage units can also be installed beneath an adjustable table. Contact our Special Orders department at special@groupelacasse.com.

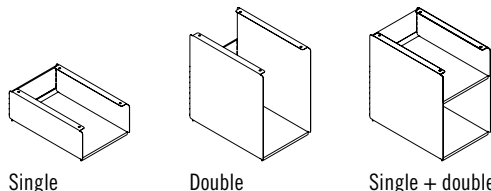

Single Double Single + double

LAMINATE STORAGE FURNITURE

General characteristics:

- Personal storage towers, wardrobes, storage units with lateral opening compartment and low storage units are freestanding and can be used alone.
- Levelers installed on laminate storage furniture allow a vertical adjustment of 1¹/₂" (38 mm).
- Face panels and doors cover the outer sides, the top, the base and the inset back. They provide an impeccable finish and solidity.

- All laminate storage units are equipped with a standard lock and 2 keys per lock. All locks are easily changed at the installation job site. It is possible to change the cylinders and to install a single-key system. A master key and control key are also available. Contact Customer Service for full details.

Center-mounted hutches

- Center-mounted hutches are installed to the top of a panel with 2 supports, supplied.
- They are held securely in place with an anti-dislodgement device.
- A top cap is necessary, depending on the configuration (refer to page 7).
- They are installed on panels having a maximum height of 54⁵/₈" (1386 mm).
- They cannot be installed on a stackable panel or on a segmented panel with glass.

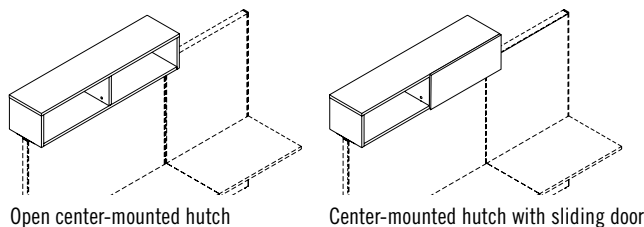

Open center-mounted hutch Center-mounted hutch with sliding door

Height management

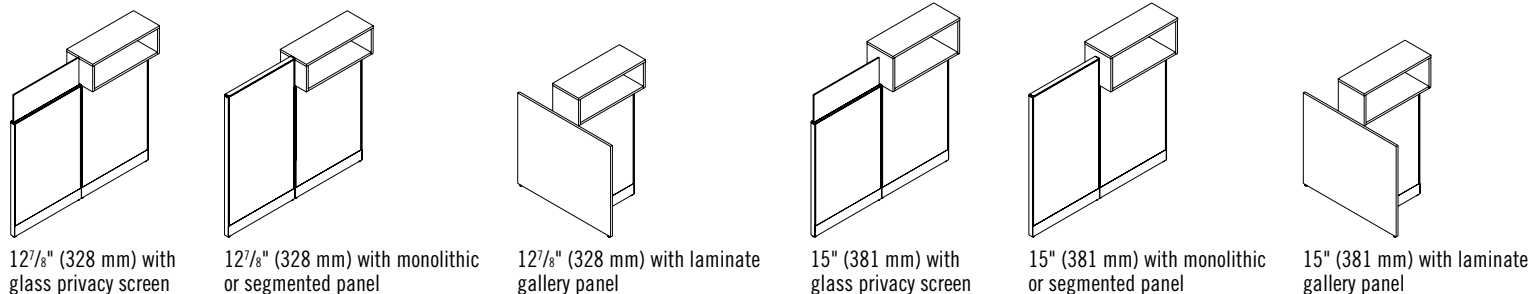

12⁷/₈" (328 mm) with glass privacy screen 12⁷/₈" (328 mm) with monolithic or segmented panel 12⁷/₈" (328 mm) with laminate gallery panel 15" (381 mm) with glass privacy screen 15" (381 mm) with monolithic or segmented panel 15" (381 mm) with laminate gallery panel

LAMINATE STORAGE FURNITURE (cont'd)

Suspended storage unit with drop-down door

- Assisted-opening, drop-down door.
- Available with choice of top or bottom shelves, for optimal set-ups in small spaces.
- Cantilevered shelves available in 12" (305 mm) or 24" (610 mm) widths.
- Suspended storage unit with a top shelf must be fastened to a work surface using the hardware included.
- We recommend not installing a work surface or a suspended storage unit with drop-down door at a height exceeding 42" (1067 mm).
- Suspended storage unit is secured in place by an anti-dislodgement device.
- The supports are located at the rear of the suspended storage unit, which must be installed on a panel of equal width, not including the width of the cantilevered shelf.
- For a suspended storage unit with drop-down door and a bottom shelf, a supplemental bracket must be ordered separately to reinforce the shelf (refer to page 13).
- **Warning:** Suspended storage units cannot be used as a seat under any circumstances.

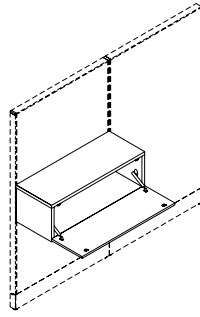

Suspended storage unit with drop-down door

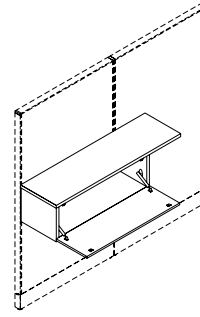

Suspended storage unit with drop-down door and upper shelf

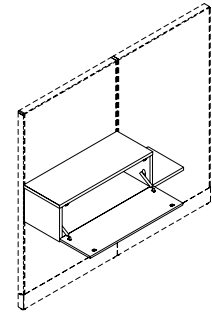

Suspended storage unit with drop-down door and lower shelf

Storage modules

- Fixed storage modules must be combined with a corner or end support in order to properly support the work surface.
- Personal storage towers, wardrobes, and storage units with lateral opening compartment may be fastened to a surface with the brackets included.
- The storage unit with lateral opening compartment has two functions: it can divide a space and be used for personal storage.

- Low storage modules can be used with an intermediate base to support a work surface.
- Cushions are available for low storage modules.

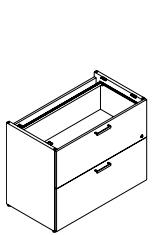

Modular lateral file

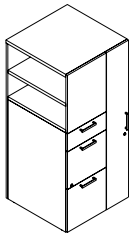

Personal storage tower

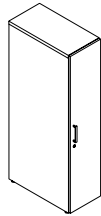

Wardrobe

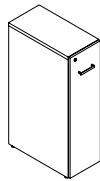

Storage unit with lateral opening compartment

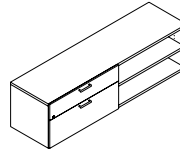
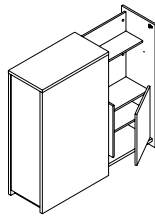

Low storage module

PANELS AND PANEL COMPONENTS

MONOLITHIC, SEGMENTED, STACKABLE PANELS AND PRIVACY SCREENS

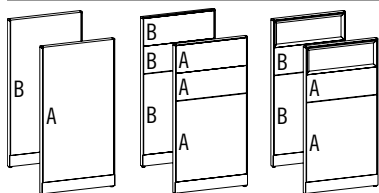

EXAMPLE: KPQLAG-6636-3P-P53-SNO-FOS-CD9-CD9-CG

A B A B

Fabric orientation: refer to swatch cards.

CODIFICATION

Series	Type of product	Finish	Panel dimension	Electrification	Finishes							
					Trim color	Panel base		Middle segment	Upper segment		Glass	
K	PM Monolithic panel	A Fabric		NN Non-powered	P53 Snow	Side A	Side B	Side A	Side B	Side A	Side B	CG Clear
	PQ Segmented panel 12 3/8" (314 mm)	L HPL		3P 3-circuit powered	P44 Metallic Silver							TG Frosted
	PH Segmented panel 24 3/4" (628 mm)	C Combined		4P 4-circuit powered	P04 Charcoal							
	PS Stackable panel	G Glass										
	PF Privacy screen											

LAMINATE GALLERY PANELS

EXAMPLE: KPLESg-4238-12-L-P53-FOS-CG

CODIFICATION

Series	Type of product	Application	Type	Option	Panel dimension	Glass height	Orientation	Finishes		
								Trim color	Laminate	Glass
K	PL Laminate gallery panel	E End-of-run	S Single	G Glass		NN None	L Left	P53 Snow		CG Clear
		M Intersection	D Shared			06 6 1/8" (157 mm)	R Right	P44 Metallic Silver		TG Frosted
						12 12 3/8" (314 mm)		P04 Charcoal		

W x D x H (in)	W x D x H (mm)	Code	Gr1 (\$)	Gr2 (\$)	Gr3 (\$)
----------------	----------------	------	----------	----------	----------

MONOLITHIC PANELS

Fabric acoustical panels, non-powered

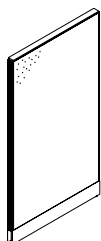

A combination of upholsteries may be applied to each side of a panel. If they are of different grades, the cost of the upholstery will be based on the price of the higher grade.

Panel includes in-line junction connectors, top trim and 2 covers with no cut-outs for the raceway.

24 x 2 x 29 7/8	610 x 51 x 758	KPMA-3024-NN-___	578	649	731
30 x 2 x 29 7/8	762 x 51 x 758	KPMA-3030-NN-___	636	706	788
36 x 2 x 29 7/8	914 x 51 x 758	KPMA-3036-NN-___	700	769	853
42 x 2 x 29 7/8	1067 x 51 x 758	KPMA-3042-NN-___	769	839	921
48 x 2 x 29 7/8	1219 x 51 x 758	KPMA-3048-NN-___	846	916	998
60 x 2 x 29 7/8	1524 x 51 x 758	KPMA-3060-NN-___	972	1,043	1,125
24 x 2 x 42 1/4	610 x 51 x 1072	KPMA-4224-NN-___	624	694	777
30 x 2 x 42 1/4	762 x 51 x 1072	KPMA-4230-NN-___	694	763	846
36 x 2 x 42 1/4	914 x 51 x 1072	KPMA-4236-NN-___	757	828	910
42 x 2 x 42 1/4	1067 x 51 x 1072	KPMA-4242-NN-___	834	904	986
48 x 2 x 42 1/4	1219 x 51 x 1072	KPMA-4248-NN-___	916	986	1,069
60 x 2 x 42 1/4	1524 x 51 x 1072	KPMA-4260-NN-___	1,057	1,125	1,210
24 x 2 x 48 3/8	610 x 51 x 1229	KPMA-4824-NN-___	655	726	808
30 x 2 x 48 3/8	762 x 51 x 1229	KPMA-4830-NN-___	719	788	870
36 x 2 x 48 3/8	914 x 51 x 1229	KPMA-4836-NN-___	795	865	947
42 x 2 x 48 3/8	1067 x 51 x 1229	KPMA-4842-NN-___	870	941	1,023
48 x 2 x 48 3/8	1219 x 51 x 1229	KPMA-4848-NN-___	955	1,023	1,108
60 x 2 x 48 3/8	1524 x 51 x 1229	KPMA-4860-NN-___	1,100	1,170	1,252
24 x 2 x 54 3/8	610 x 51 x 1386	KPMA-5424-NN-___	706	777	859
30 x 2 x 54 3/8	762 x 51 x 1386	KPMA-5430-NN-___	777	846	929
36 x 2 x 54 3/8	914 x 51 x 1386	KPMA-5436-NN-___	859	929	1,011
42 x 2 x 54 3/8	1067 x 51 x 1386	KPMA-5442-NN-___	941	1,011	1,093
48 x 2 x 54 3/8	1219 x 51 x 1386	KPMA-5448-NN-___	1,031	1,100	1,184
60 x 2 x 54 3/8	1524 x 51 x 1386	KPMA-5460-NN-___	1,184	1,252	1,335
24 x 2 x 66 7/8	610 x 51 x 1700	KPMA-6624-NN-___	757	828	910
30 x 2 x 66 7/8	762 x 51 x 1700	KPMA-6630-NN-___	834	904	986
36 x 2 x 66 7/8	914 x 51 x 1700	KPMA-6636-NN-___	916	986	1,069
42 x 2 x 66 7/8	1067 x 51 x 1700	KPMA-6642-NN-___	1,011	1,082	1,164
48 x 2 x 66 7/8	1219 x 51 x 1700	KPMA-6648-NN-___	1,113	1,184	1,266
60 x 2 x 66 7/8	1524 x 51 x 1700	KPMA-6660-NN-___	1,272	1,343	1,425

At the end of the product code add, in this order: trim color, upholstery for sides A/B.

Fabric acoustical panels, powered



A combination of upholsteries may be applied to each side of a panel. If they are of different grades, the cost of the upholstery will be based on the price of the higher grade.

W x D x H (in)	W x D x H (mm)	Code	Gr1 (\$)	Gr2 (\$)	Gr3 (\$)
----------------	----------------	------	----------	----------	----------

Panel includes in-line junction connectors, top trim, 2 covers with cut-outs and knock-out communication plates for the raceway, the electric system, and the in-line power connector. To be ordered separately: duplex receptacles KER - - -; refer to pages 29 and 30.

24 x 2 x 29 7/8	610 x 51 x 758	KPMA-3024-P-___	712	783	865
30 x 2 x 29 7/8	762 x 51 x 758	KPMA-3030-P-___	802	870	955
36 x 2 x 29 7/8	914 x 51 x 758	KPMA-3036-P-___	885	955	1,037
42 x 2 x 29 7/8	1067 x 51 x 758	KPMA-3042-P-___	955	1,023	1,108
48 x 2 x 29 7/8	1219 x 51 x 758	KPMA-3048-P-___	1,043	1,113	1,195
60 x 2 x 29 7/8	1524 x 51 x 758	KPMA-3060-P-___	1,227	1,298	1,380
24 x 2 x 42 1/4	610 x 51 x 1072	KPMA-4224-P-___	763	834	916
30 x 2 x 42 1/4	762 x 51 x 1072	KPMA-4230-P-___	859	929	1,011
36 x 2 x 42 1/4	914 x 51 x 1072	KPMA-4236-P-___	947	1,018	1,100
42 x 2 x 42 1/4	1067 x 51 x 1072	KPMA-4242-P-___	1,023	1,093	1,177
48 x 2 x 42 1/4	1219 x 51 x 1072	KPMA-4248-P-___	1,113	1,184	1,266
60 x 2 x 42 1/4	1524 x 51 x 1072	KPMA-4260-P-___	1,317	1,386	1,470
24 x 2 x 48 3/8	610 x 51 x 1229	KPMA-4824-P-___	788	859	941
30 x 2 x 48 3/8	762 x 51 x 1229	KPMA-4830-P-___	890	961	1,043
36 x 2 x 48 3/8	914 x 51 x 1229	KPMA-4836-P-___	980	1,049	1,133
42 x 2 x 48 3/8	1067 x 51 x 1229	KPMA-4842-P-___	1,057	1,125	1,210
48 x 2 x 48 3/8	1219 x 51 x 1229	KPMA-4848-P-___	1,151	1,221	1,303
60 x 2 x 48 3/8	1524 x 51 x 1229	KPMA-4860-P-___	1,354	1,425	1,507
24 x 2 x 54 3/8	610 x 51 x 1386	KPMA-5424-P-___	839	910	992
30 x 2 x 54 3/8	762 x 51 x 1386	KPMA-5430-P-___	947	1,018	1,100
36 x 2 x 54 3/8	914 x 51 x 1386	KPMA-5436-P-___	1,043	1,113	1,195
42 x 2 x 54 3/8	1067 x 51 x 1386	KPMA-5442-P-___	1,133	1,201	1,285
48 x 2 x 54 3/8	1219 x 51 x 1386	KPMA-5448-P-___	1,227	1,298	1,380
60 x 2 x 54 3/8	1524 x 51 x 1386	KPMA-5460-P-___	1,444	1,514	1,596
24 x 2 x 66 7/8	610 x 51 x 1700	KPMA-6624-P-___	896	967	1,049
30 x 2 x 66 7/8	762 x 51 x 1700	KPMA-6630-P-___	1,006	1,074	1,159
36 x 2 x 66 7/8	914 x 51 x 1700	KPMA-6636-P-___	1,108	1,177	1,260
42 x 2 x 66 7/8	1067 x 51 x 1700	KPMA-6642-P-___	1,201	1,272	1,354
48 x 2 x 66 7/8	1219 x 51 x 1700	KPMA-6648-P-___	1,303	1,374	1,456
60 x 2 x 66 7/8	1524 x 51 x 1700	KPMA-6660-P-___	1,533	1,603	1,685

Specify 3-circuit or 4-circuit system (surcharge of \$140 for 4-circuit). At the end of the product code add, in this order: trim color, upholstery for sides A/B.

Laminate panels, non-powered

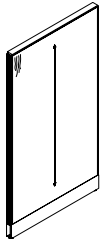

A combination of HPL finishes may be applied to each side of a panel.

W x D x H (in)	W x D x H (mm)	Code	Price (\$)
<i>Panel includes in-line junction connectors, top trim and 2 covers with no cut-outs for raceway.</i>			
24 x 2 x 29 ⁷ / ₈	610 x 51 x 758	KPML-3024-NN-___	980
30 x 2 x 29 ⁷ / ₈	762 x 51 x 758	KPML-3030-NN-___	1,026
36 x 2 x 29 ⁷ / ₈	914 x 51 x 758	KPML-3036-NN-___	1,073
42 x 2 x 29 ⁷ / ₈	1067 x 51 x 758	KPML-3042-NN-___	1,225
48 x 2 x 29 ⁷ / ₈	1219 x 51 x 758	KPML-3048-NN-___	1,273
24 x 2 x 42 ¹ / ₄	610 x 51 x 1072	KPML-4224-NN-___	1,113
30 x 2 x 42 ¹ / ₄	762 x 51 x 1072	KPML-4230-NN-___	1,160
36 x 2 x 42 ¹ / ₄	914 x 51 x 1072	KPML-4236-NN-___	1,207
42 x 2 x 42 ¹ / ₄	1067 x 51 x 1072	KPML-4242-NN-___	1,426
48 x 2 x 42 ¹ / ₄	1219 x 51 x 1072	KPML-4248-NN-___	1,473
24 x 2 x 48 ³ / ₈	610 x 51 x 1229	KPML-4824-NN-___	1,180
30 x 2 x 48 ³ / ₈	762 x 51 x 1229	KPML-4830-NN-___	1,225
36 x 2 x 48 ³ / ₈	914 x 51 x 1229	KPML-4836-NN-___	1,279
42 x 2 x 48 ³ / ₈	1067 x 51 x 1229	KPML-4842-NN-___	1,526
48 x 2 x 48 ³ / ₈	1219 x 51 x 1229	KPML-4848-NN-___	1,572
24 x 2 x 54 ³ / ₈	610 x 51 x 1386	KPML-5424-NN-___	1,246
30 x 2 x 54 ³ / ₈	762 x 51 x 1386	KPML-5430-NN-___	1,300
36 x 2 x 54 ³ / ₈	914 x 51 x 1386	KPML-5436-NN-___	1,346
42 x 2 x 54 ³ / ₈	1067 x 51 x 1386	KPML-5442-NN-___	1,626
48 x 2 x 54 ³ / ₈	1219 x 51 x 1386	KPML-5448-NN-___	1,673
24 x 2 x 66 ⁷ / ₈	610 x 51 x 1700	KPML-6624-NN-___	1,279
30 x 2 x 66 ⁷ / ₈	762 x 51 x 1700	KPML-6630-NN-___	1,326
36 x 2 x 66 ⁷ / ₈	914 x 51 x 1700	KPML-6636-NN-___	1,373
42 x 2 x 66 ⁷ / ₈	1067 x 51 x 1700	KPML-6642-NN-___	1,686
48 x 2 x 66 ⁷ / ₈	1219 x 51 x 1700	KPML-6648-NN-___	1,733

At the end of the product code add, in this order: trim color, HPL finishes for sides A/B.

Laminate panels, powered

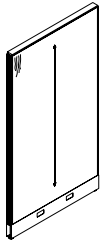

A combination of HPL finishes may be applied to each side of a panel.

W x D x H (in)	W x D x H (mm)	Code	Price (\$)
<i>Panel includes in-line junction connectors, top trim, 2 covers with cut-outs and knock-out communication plates for the raceway, the electric system, and the in-line power connector. To be ordered separately: duplex receptacles KER - - - -; refer to pages 29 and 30.</i>			
24 x 2 x 29 ⁷ / ₈	610 x 51 x 758	KPML-3024- P-___	1,119
30 x 2 x 29 ⁷ / ₈	762 x 51 x 758	KPML-3030- P-___	1,199
36 x 2 x 29 ⁷ / ₈	914 x 51 x 758	KPML-3036- P-___	1,266
42 x 2 x 29 ⁷ / ₈	1067 x 51 x 758	KPML-3042- P-___	1,421
48 x 2 x 29 ⁷ / ₈	1219 x 51 x 758	KPML-3048- P-___	1,480
24 x 2 x 42 ¹ / ₄	610 x 51 x 1072	KPML-4224- P-___	1,252
30 x 2 x 42 ¹ / ₄	762 x 51 x 1072	KPML-4230- P-___	1,332
36 x 2 x 42 ¹ / ₄	914 x 51 x 1072	KPML-4236- P-___	1,400
42 x 2 x 42 ¹ / ₄	1067 x 51 x 1072	KPML-4242- P-___	1,619
48 x 2 x 42 ¹ / ₄	1219 x 51 x 1072	KPML-4248- P-___	1,679
24 x 2 x 48 ³ / ₈	610 x 51 x 1229	KPML-4824- P-___	1,320
30 x 2 x 48 ³ / ₈	762 x 51 x 1229	KPML-4830- P-___	1,400
36 x 2 x 48 ³ / ₈	914 x 51 x 1229	KPML-4836- P-___	1,473
42 x 2 x 48 ³ / ₈	1067 x 51 x 1229	KPML-4842- P-___	1,719
48 x 2 x 48 ³ / ₈	1219 x 51 x 1229	KPML-4848- P-___	1,779
24 x 2 x 54 ³ / ₈	610 x 51 x 1386	KPML-5424- P-___	1,385
30 x 2 x 54 ³ / ₈	762 x 51 x 1386	KPML-5430- P-___	1,473
36 x 2 x 54 ³ / ₈	914 x 51 x 1386	KPML-5436- P-___	1,540
42 x 2 x 54 ³ / ₈	1067 x 51 x 1386	KPML-5442- P-___	1,819
48 x 2 x 54 ³ / ₈	1219 x 51 x 1386	KPML-5448- P-___	1,878
24 x 2 x 66 ⁷ / ₈	610 x 51 x 1700	KPML-6624- P-___	1,421
30 x 2 x 66 ⁷ / ₈	762 x 51 x 1700	KPML-6630- P-___	1,500
36 x 2 x 66 ⁷ / ₈	914 x 51 x 1700	KPML-6636- P-___	1,566
42 x 2 x 66 ⁷ / ₈	1067 x 51 x 1700	KPML-6642- P-___	1,878
48 x 2 x 66 ⁷ / ₈	1219 x 51 x 1700	KPML-6648- P-___	1,940

Specify 3-circuit or 4-circuit system (surcharge of \$140 for 4-circuit).

At the end of the product code add, in this order: trim color, HPL finishes for sides A/B.

Laminate/fabric combined panels, non-powered

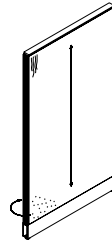

W x D x H (in)	W x D x H (mm)	Code	Gr1 (\$)	Gr2 (\$)	Gr3 (\$)
<i>Panel includes in-line junction connectors, top trim and 2 covers with no cut-outs for raceway.</i>					
24 x 2 x 29 ⁷ / ₈	610 x 51 x 758	KPMC-3024-NN-___	885	921	967
30 x 2 x 29 ⁷ / ₈	762 x 51 x 758	KPMC-3030-NN-___	941	980	1,023
36 x 2 x 29 ⁷ / ₈	914 x 51 x 758	KPMC-3036-NN-___	992	1,031	1,074
42 x 2 x 29 ⁷ / ₈	1067 x 51 x 758	KPMC-3042-NN-___	1,100	1,139	1,184
48 x 2 x 29 ⁷ / ₈	1219 x 51 x 758	KPMC-3048-NN-___	1,151	1,190	1,234
24 x 2 x 42 ¹ / ₄	610 x 51 x 1072	KPMC-4224-NN-___	1,006	1,043	1,088
30 x 2 x 42 ¹ / ₄	762 x 51 x 1072	KPMC-4230-NN-___	1,062	1,100	1,144
36 x 2 x 42 ¹ / ₄	914 x 51 x 1072	KPMC-4236-NN-___	1,119	1,159	1,201
42 x 2 x 42 ¹ / ₄	1067 x 51 x 1072	KPMC-4242-NN-___	1,252	1,292	1,335
48 x 2 x 42 ¹ / ₄	1219 x 51 x 1072	KPMC-4248-NN-___	1,303	1,343	1,386
24 x 2 x 48 ³ / ₈	610 x 51 x 1229	KPMC-4824-NN-___	1,069	1,108	1,151
30 x 2 x 48 ³ / ₈	762 x 51 x 1229	KPMC-4830-NN-___	1,125	1,164	1,210
36 x 2 x 48 ³ / ₈	914 x 51 x 1229	KPMC-4836-NN-___	1,177	1,215	1,260
42 x 2 x 48 ³ / ₈	1067 x 51 x 1229	KPMC-4842-NN-___	1,329	1,368	1,412
48 x 2 x 48 ³ / ₈	1219 x 51 x 1229	KPMC-4848-NN-___	1,380	1,419	1,463
24 x 2 x 54 ³ / ₈	610 x 51 x 1386	KPMC-5424-NN-___	1,133	1,170	1,215
30 x 2 x 54 ³ / ₈	762 x 51 x 1386	KPMC-5430-NN-___	1,184	1,221	1,266
36 x 2 x 54 ³ / ₈	914 x 51 x 1386	KPMC-5436-NN-___	1,241	1,278	1,323
42 x 2 x 54 ³ / ₈	1067 x 51 x 1386	KPMC-5442-NN-___	1,405	1,444	1,488
48 x 2 x 54 ³ / ₈	1219 x 51 x 1386	KPMC-5448-NN-___	1,463	1,502	1,545
24 x 2 x 66 ⁷ / ₈	610 x 51 x 1700	KPMC-6624-NN-___	1,252	1,292	1,335
30 x 2 x 66 ⁷ / ₈	762 x 51 x 1700	KPMC-6630-NN-___	1,303	1,343	1,386
36 x 2 x 66 ⁷ / ₈	914 x 51 x 1700	KPMC-6636-NN-___	1,361	1,400	1,444
42 x 2 x 66 ⁷ / ₈	1067 x 51 x 1700	KPMC-6642-NN-___	1,558	1,596	1,642
48 x 2 x 66 ⁷ / ₈	1219 x 51 x 1700	KPMC-6648-NN-___	1,616	1,654	1,698

At the end of the product code add, in this order: trim color, HPL finish for side A, upholstery for side B.

Laminate/fabric combined panels, powered

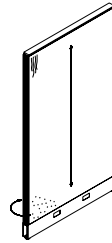

W x D x H (in)	W x D x H (mm)	Code	Gr1 (\$)	Gr2 (\$)	Gr3 (\$)
<i>Panel includes in-line junction connectors, top trim, 2 covers with cut-outs and knock-out communication plates for the raceway, the electric system, and the in-line power connector. To be ordered separately: duplex receptacles KER - - - -; refer to pages 29 and 30.</i>					
24 x 2 x 29 ⁷ / ₈	610 x 51 x 758	KPMC-3024- P-___	1,018	1,057	1,100
30 x 2 x 29 ⁷ / ₈	762 x 51 x 758	KPMC-3030- P-___	1,108	1,144	1,190
36 x 2 x 29 ⁷ / ₈	914 x 51 x 758	KPMC-3036- P-___	1,177	1,215	1,260
42 x 2 x 29 ⁷ / ₈	1067 x 51 x 758	KPMC-3042- P-___	1,285	1,323	1,368
48 x 2 x 29 ⁷ / ₈	1219 x 51 x 758	KPMC-3048- P-___	1,349	1,386	1,431
24 x 2 x 42 ¹ / ₄	610 x 51 x 1072	KPMC-4224- P-___	1,139	1,177	1,221
30 x 2 x 42 ¹ / ₄	762 x 51 x 1072	KPMC-4230- P-___	1,227	1,266	1,310
36 x 2 x 42 ¹ / ₄	914 x 51 x 1072	KPMC-4236- P-___	1,303	1,343	1,386
42 x 2 x 42 ¹ / ₄	1067 x 51 x 1072	KPMC-4242- P-___	1,437	1,476	1,520
48 x 2 x 42 ¹ / ₄	1219 x 51 x 1072	KPMC-4248- P-___	1,502	1,540	1,584
24 x 2 x 48 ³ / ₈	610 x 51 x 1229	KPMC-4824- P-___	1,201	1,241	1,285
30 x 2 x 48 ³ / ₈	762 x 51 x 1229	KPMC-4830- P-___	1,292	1,329	1,374
36 x 2 x 48 ³ / ₈	914 x 51 x 1229	KPMC-4836- P-___	1,361	1,400	1,444
42 x 2 x 48 ³ / ₈	1067 x 51 x 1229	KPMC-4842- P-___	1,514	1,552	1,596
48 x 2 x 48 ³ / ₈	1219 x 51 x 1229	KPMC-4848- P-___	1,577	1,616	1,659
24 x 2 x 54 ³ / ₈	610 x 51 x 1386	KPMC-5424- P-___	1,266	1,303	1,349
30 x 2 x 54 ³ / ₈	762 x 51 x 1386	KPMC-5430- P-___	1,349	1,386	1,431
36 x 2 x 54 ³ / ₈	914 x 51 x 1386	KPMC-5436- P-___	1,425	1,463	1,507
42 x 2 x 54 ³ / ₈	1067 x 51 x 1386	KPMC-5442- P-___	1,591	1,628	1,673
48 x 2 x 54 ³ / ₈	1219 x 51 x 1386	KPMC-5448- P-___	1,659	1,698	1,743
24 x 2 x 66 ⁷ / ₈	610 x 51 x 1700	KPMC-6624- P-___	1,386	1,425	1,470
30 x 2 x 66 ⁷ / ₈	762 x 51 x 1700	KPMC-6630- P-___	1,470	1,507	1,552
36 x 2 x 66 ⁷ / ₈	914 x 51 x 1700	KPMC-6636- P-___	1,545	1,584	1,628
42 x 2 x 66 ⁷ / ₈	1067 x 51 x 1700	KPMC-6642- P-___	1,743	1,780	1,826
48 x 2 x 66 ⁷ / ₈	1219 x 51 x 1700	KPMC-6648- P-___	1,813	1,850	1,896

Specify 3-circuit or 4-circuit system (surcharge of \$140 for 4-circuit). At the end of the product code add, in this order: trim color, HPL finish for side A, upholstery for side B.

W x D x H (in)	W x D x H (mm)	Code	Gr1 (\$)	Gr2 (\$)	Gr3 (\$)
SEGMENTED PANELS – 1 GLASS UPPER SEGMENT					
Fabric acoustical panels, 12 3/8" H glass segment, non-powered					
<i>Panel includes the tempered glass segment, in-line junction connectors, top trim and 2 covers with no cut-outs for raceway.</i>					
24 x 2 x 42 1/4	610 x 51 x 1072	KPQAG-4224-NN	1,252	1,323	1,405
30 x 2 x 42 1/4	762 x 51 x 1072	KPQAG-4230-NN	1,354	1,425	1,507
36 x 2 x 42 1/4	914 x 51 x 1072	KPQAG-4236-NN	1,476	1,545	1,628
42 x 2 x 42 1/4	1067 x 51 x 1072	KPQAG-4242-NN	1,596	1,667	1,749
48 x 2 x 42 1/4	1219 x 51 x 1072	KPQAG-4248-NN	1,736	1,806	1,889
60 x 2 x 42 1/4	1524 x 51 x 1072	KPQAG-4260-NN	1,958	2,029	2,111
24 x 2 x 54 3/8	610 x 51 x 1386	KPQAG-5424-NN	1,303	1,374	1,456
30 x 2 x 54 3/8	762 x 51 x 1386	KPQAG-5430-NN	1,412	1,482	1,565
36 x 2 x 54 3/8	914 x 51 x 1386	KPQAG-5436-NN	1,533	1,603	1,685
42 x 2 x 54 3/8	1067 x 51 x 1386	KPQAG-5442-NN	1,667	1,736	1,819
48 x 2 x 54 3/8	1219 x 51 x 1386	KPQAG-5448-NN	1,806	1,876	1,958
60 x 2 x 54 3/8	1524 x 51 x 1386	KPQAG-5460-NN	2,040	2,111	2,193
24 x 2 x 66 7/8	610 x 51 x 1700	KPQAG-6624-NN	1,329	1,400	1,482
30 x 2 x 66 7/8	762 x 51 x 1700	KPQAG-6630-NN	1,444	1,514	1,596
36 x 2 x 66 7/8	914 x 51 x 1700	KPQAG-6636-NN	1,565	1,634	1,718
42 x 2 x 66 7/8	1067 x 51 x 1700	KPQAG-6642-NN	1,698	1,768	1,850
48 x 2 x 66 7/8	1219 x 51 x 1700	KPQAG-6648-NN	1,845	1,915	1,998
60 x 2 x 66 7/8	1524 x 51 x 1700	KPQAG-6660-NN	2,086	2,157	2,239
At the end of the product code add, in this order: trim color, upholstery for sides A/B, clear (CG) or frosted (TG) finish for tempered glass (TG, surcharge of \$63).					

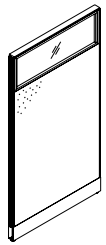

A combination of upholsteries may be applied to each side of a panel. If they are of different grades, the cost of the upholstery will be based on the price of the higher grade.

W x D x H (in)	W x D x H (mm)	Code	Gr1 (\$)	Gr2 (\$)	Gr3 (\$)
Fabric acoustical panels, 12 3/8" H glass segment, powered					
<i>Panel includes the tempered glass segment, in-line junction connectors, top trim, 2 covers with cut-outs and knock-out communication plates for the raceway, the electric system and the in-line power connector. To be ordered separately: duplex receptacles KER - - -; refer to pages 29 and 30.</i>					
24 x 2 x 42 1/4	610 x 51 x 1072	KPQAG-4224-P	1,394	1,463	1,545
30 x 2 x 42 1/4	762 x 51 x 1072	KPQAG-4230-P	1,526	1,596	1,679
36 x 2 x 42 1/4	914 x 51 x 1072	KPQAG-4236-P	1,659	1,730	1,813
42 x 2 x 42 1/4	1067 x 51 x 1072	KPQAG-4242-P	1,787	1,857	1,940
48 x 2 x 42 1/4	1219 x 51 x 1072	KPQAG-4248-P	1,934	2,003	2,086
60 x 2 x 42 1/4	1524 x 51 x 1072	KPQAG-4260-P	2,219	2,290	2,372
24 x 2 x 54 3/8	610 x 51 x 1386	KPQAG-5424-P	1,437	1,507	1,591
30 x 2 x 54 3/8	762 x 51 x 1386	KPQAG-5430-P	1,577	1,647	1,730
36 x 2 x 54 3/8	914 x 51 x 1386	KPQAG-5436-P	1,718	1,787	1,870
42 x 2 x 54 3/8	1067 x 51 x 1386	KPQAG-5442-P	1,850	1,921	2,003
48 x 2 x 54 3/8	1219 x 51 x 1386	KPQAG-5448-P	2,003	2,074	2,157
60 x 2 x 54 3/8	1524 x 51 x 1386	KPQAG-5460-P	2,303	2,372	2,455
24 x 2 x 66 7/8	610 x 51 x 1700	KPQAG-6624-P	1,463	1,533	1,616
30 x 2 x 66 7/8	762 x 51 x 1700	KPQAG-6630-P	1,608	1,679	1,761
36 x 2 x 66 7/8	914 x 51 x 1700	KPQAG-6636-P	1,756	1,826	1,908
42 x 2 x 66 7/8	1067 x 51 x 1700	KPQAG-6642-P	1,889	1,958	2,040
48 x 2 x 66 7/8	1219 x 51 x 1700	KPQAG-6648-P	2,040	2,111	2,193
60 x 2 x 66 7/8	1524 x 51 x 1700	KPQAG-6660-P	2,346	2,416	2,499
Specify 3-circuit or 4-circuit system (surcharge of \$140 for 4-circuit). At the end of the product code add, in this order: trim color, upholstery for sides A/B, clear (CG) or frosted (TG) finish for tempered glass (TG, surcharge of \$63).					

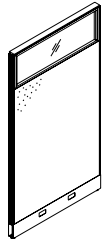

A combination of upholsteries may be applied to each side of a panel. If they are of different grades, the cost of the upholstery will be based on the price of the higher grade.

W x D x H (in)	W x D x H (mm)	Code	Gr1 (\$)	Gr2 (\$)	Gr3 (\$)
Laminate panels, 12 3/8" H glass segment, non-powered					
<i>Panel includes the tempered glass segment, in-line junction connectors, top trim, and 2 covers with no cut-outs for raceway.</i>					
24 x 2 x 42 1/4	610 x 51 x 1072	KPQLG-4224-NN			1,686
30 x 2 x 42 1/4	762 x 51 x 1072	KPQLG-4230-NN			1,779
36 x 2 x 42 1/4	914 x 51 x 1072	KPQLG-4236-NN			1,887
42 x 2 x 42 1/4	1067 x 51 x 1072	KPQLG-4242-NN			2,091
48 x 2 x 42 1/4	1219 x 51 x 1072	KPQLG-4248-NN			2,207
24 x 2 x 54 3/8	610 x 51 x 1386	KPQLG-5424-NN			1,819
30 x 2 x 54 3/8	762 x 51 x 1386	KPQLG-5430-NN			1,913
36 x 2 x 54 3/8	914 x 51 x 1386	KPQLG-5436-NN			2,020
42 x 2 x 54 3/8	1067 x 51 x 1386	KPQLG-5442-NN			2,292
48 x 2 x 54 3/8	1219 x 51 x 1386	KPQLG-5448-NN			2,406

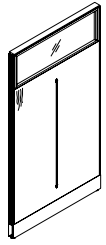

W x D x H (in)	W x D x H (mm)	Code	Gr1 (\$)	Gr2 (\$)	Gr3 (\$)
Laminate panels, 12 3/8" H glass segment, non-powered (cont'd)					
<i>A combination of HPL finishes may be applied to each side of a panel.</i>					
24 x 2 x 66 7/8	610 x 51 x 1700	KPQLG-6624-NN			1,952
30 x 2 x 66 7/8	762 x 51 x 1700	KPQLG-6630-NN			2,052
36 x 2 x 66 7/8	914 x 51 x 1700	KPQLG-6636-NN			2,159
42 x 2 x 66 7/8	1067 x 51 x 1700	KPQLG-6642-NN			2,492
48 x 2 x 66 7/8	1219 x 51 x 1700	KPQLG-6648-NN			2,605
At the end of the product code add, in this order: trim color, HPL finishes for sides A/B, clear (CG) or frosted (TG) finish for tempered glass (TG, surcharge of \$63).					

W x D x H (in)	W x D x H (mm)	Code	Gr1 (\$)	Gr2 (\$)	Gr3 (\$)
Laminate panels, 12 3/8" H glass segment, powered					
<i>Panel includes the tempered glass segment, in-line junction connectors, top trim, 2 covers with cut-outs and knock-out communication plates for the raceway, the electric system and the in-line power connector. To be ordered separately: duplex receptacles KER - - -; refer to pages 29 and 30.</i>					
24 x 2 x 42 1/4	610 x 51 x 1072	KPQLG-4224-P			1,826
30 x 2 x 42 1/4	762 x 51 x 1072	KPQLG-4230-P			1,958
36 x 2 x 42 1/4	914 x 51 x 1072	KPQLG-4236-P			2,079
42 x 2 x 42 1/4	1067 x 51 x 1072	KPQLG-4242-P			2,292
48 x 2 x 42 1/4	1219 x 51 x 1072	KPQLG-4248-P			2,412
24 x 2 x 54 3/8	610 x 51 x 1386	KPQLG-5424-P			1,958
30 x 2 x 54 3/8	762 x 51 x 1386	KPQLG-5430-P			2,091
36 x 2 x 54 3/8	914 x 51 x 1386	KPQLG-5436-P			2,212
42 x 2 x 54 3/8	1067 x 51 x 1386	KPQLG-5442-P			2,492
48 x 2 x 54 3/8	1219 x 51 x 1386	KPQLG-5448-P			2,612
24 x 2 x 66 7/8	610 x 51 x 1700	KPQLG-6624-P			2,091
30 x 2 x 66 7/8	762 x 51 x 1700	KPQLG-6630-P			2,233
36 x 2 x 66 7/8	914 x 51 x 1700	KPQLG-6636-P			2,352
42 x 2 x 66 7/8	1067 x 51 x 1700	KPQLG-6642-P			2,693
48 x 2 x 66 7/8	1219 x 51 x 1700	KPQLG-6648-P			2,812
Specify 3-circuit or 4-circuit system (surcharge of \$140 for 4-circuit). At the end of the product code add, in this order: trim color, HPL finishes for sides A/B, clear (CG) or frosted (TG) finish for tempered glass (TG, surcharge of \$63).					

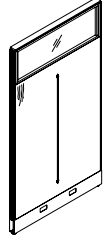

A combination of HPL finishes may be applied to each side of a panel.

W x D x H (in)	W x D x H (mm)	Code	Gr1 (\$)	Gr2 (\$)	Gr3 (\$)
Laminate/fabric combined panels, 12 3/8" H glass segment, non-powered					
<i>Panel includes the tempered glass segment, in-line junction connectors, top trim, and 2 covers with no cut-outs for raceway.</i>					
24 x 2 x 42 1/4	610 x 51 x 1072	KPQCG-4224-NN	1,558	1,596	1,642
30 x 2 x 42 1/4	762 x 51 x 1072	KPQCG-4230-NN	1,659	1,698	1,743
36 x 2 x 42 1/4	914 x 51 x 1072	KPQCG-4236-NN	1,768	1,806	1,850
42 x 2 x 42 1/4	1067 x 51 x 1072	KPQCG-4242-NN	1,927	1,966	2,009
48 x 2 x 42 1/4	1219 x 51 x 1072	KPQCG-4248-NN	2,040	2,080	2,125
24 x 2 x 54 3/8	610 x 51 x 1386	KPQCG-5424-NN	1,679	1,718	1,761
30 x 2 x 54 3/8	762 x 51 x 1386	KPQCG-5430-NN	1,780	1,819	1,864
36 x 2 x 54 3/8	914 x 51 x 1386	KPQCG-5436-NN	1,896	1,934	1,978
42 x 2 x 54 3/8	1067 x 51 x 1386	KPQCG-5442-NN	2,080	2,117	2,162
48 x 2 x 54 3/8	1219 x 51 x 1386	KPQCG-5448-NN	2,193	2,233	2,278
24 x 2 x 66 7/8	610 x 51 x 1700	KPQCG-6624-NN	1,743	1,780	1,826
30 x 2 x 66 7/8	762 x 51 x 1700	KPQCG-6630-NN	1,845	1,882	1,927
36 x 2 x 66 7/8	914 x 51 x 1700	KPQCG-6636-NN	1,952	1,991	2,035
42 x 2 x 66 7/8	1067 x 51 x 1700	KPQCG-6642-NN	2,157	2,193	2,239
48 x 2 x 66 7/8	1219 x 51 x 1700	KPQCG-6648-NN	2,270	2,309	2,354
At the end of the product code add, in this order: trim color, HPL finish for side A, upholstery for side B, clear (CG) or frosted (TG) finish for tempered glass (TG, surcharge of \$63).					

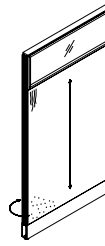

W x D x H (in)	W x D x H (mm)	Code	Gr1 (\$)	Gr2 (\$)	Gr3 (\$)
Laminate/fabric combined panels, 12 3/8" H, glass segment, powered					
<i>Panel includes the tempered glass segment, in-line junction connectors, top trim, 2 covers with cut-outs and knock-out communication plates for the raceway, the electric system and the in-line power connector. To be ordered separately: duplex receptacles KER - - -; refer to pages 29 and 30.</i>					
24 x 2 x 42 1/4	610 x 51 x 1072	KPQCG-4224-P	1,693	1,730	1,775
30 x 2 x 42 1/4	762 x 51 x 1072	KPQCG-4230-P	1,831	1,870	1,915
36 x 2 x 42 1/4	914 x 51 x 1072	KPQCG-4236-P	1,952	1,991	2,035
42 x 2 x 42 1/4	1067 x 51 x 1072	KPQCG-4242-P	2,117	2,157	2,201
48 x 2 x 42 1/4	1219 x 51 x 1072	KPQCG-4248-P	2,239	2,278	2,321
24 x 2 x 54 3/8	610 x 51 x 1386	KPQCG-5424-P	1,813	1,850	1,896
30 x 2 x 54 3/8	762 x 51 x 1386	KPQCG-5430-P	1,952	1,991	2,035
36 x 2 x 54 3/8	914 x 51 x 1386	KPQCG-5436-P	2,080	2,117	2,162
42 x 2 x 54 3/8	1067 x 51 x 1386	KPQCG-5442-P	2,270	2,309	2,354
48 x 2 x 54 3/8	1219 x 51 x 1386	KPQCG-5448-P	2,391	2,430	2,473

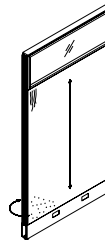

PARADIGM Panel System

	W x D x H (in)	W x D x H (mm)	Code	Gr1 (\$)	Gr2 (\$)	Gr3 (\$)
Laminate/fabric combined panels, 12 3/8" H glass segment, powered (cont'd)	24 x 2 x 66 7/8	610 x 51 x 1700	KPQCG-6624- P-	1,876	1,915	1,958
	30 x 2 x 66 7/8	762 x 51 x 1700	KPQCG-6630- P-	2,017	2,055	2,100
	36 x 2 x 66 7/8	914 x 51 x 1700	KPQCG-6636- P-	2,137	2,176	2,219
	42 x 2 x 66 7/8	1067 x 51 x 1700	KPQCG-6642- P-	2,346	2,385	2,430
	48 x 2 x 66 7/8	1219 x 51 x 1700	KPQCG-6648- P-	2,467	2,506	2,550

Specify 3-circuit or 4-circuit system (surcharge of \$140 for 4-circuit). At the end of the product code add, in this order: trim color, HPL finish for side A, upholstery for side B, clear (CG) or frosted (TG) finish for tempered glass (TG, surcharge of \$63).

	W x D x H (in)	W x D x H (mm)	Code	Gr1 (\$)	Gr2 (\$)	Gr3 (\$)
Fabric acoustical panels, 24 3/4" H glass segment, non-powered	<i>Panel includes the tempered glass segment, in-line junction connectors, top trim, and 2 covers with no cut-outs for raceway.</i>					
	24 x 2 x 54 3/8	610 x 51 x 1386	KPHAG-5424- NN-	1,335	1,405	1,488
	30 x 2 x 54 3/8	762 x 51 x 1386	KPHAG-5430- NN-	1,444	1,514	1,596
	36 x 2 x 54 3/8	914 x 51 x 1386	KPHAG-5436- NN-	1,565	1,634	1,718
	42 x 2 x 54 3/8	1067 x 51 x 1386	KPHAG-5442- NN-	1,698	1,768	1,850
	48 x 2 x 54 3/8	1219 x 51 x 1386	KPHAG-5448- NN-	1,845	1,915	1,998
	60 x 2 x 54 3/8	1524 x 51 x 1386	KPHAG-5460- NN-	2,091	2,162	2,244
	24 x 2 x 66 7/8	610 x 51 x 1700	KPHAG-6624- NN-	1,380	1,451	1,533
	30 x 2 x 66 7/8	762 x 51 x 1700	KPHAG-6630- NN-	1,502	1,571	1,654
	36 x 2 x 66 7/8	914 x 51 x 1700	KPHAG-6636- NN-	1,628	1,698	1,780

At the end of the product code add, in this order: trim color, upholstery for sides A/B, clear (CG) or frosted (TG) finish for tempered glass (TG, surcharge of \$153).

42 x 2 x 66 7/8	1067 x 51 x 1700	KPHAG-6642- NN-	1,768	1,838	1,921
48 x 2 x 66 7/8	1219 x 51 x 1700	KPHAG-6648- NN-	1,927	1,998	2,080
60 x 2 x 66 7/8	1524 x 51 x 1700	KPHAG-6660- NN-	2,176	2,244	2,329

At the end of the product code add, in this order: trim color, upholstery for sides A/B, clear (CG) or frosted (TG) finish for tempered glass (TG, surcharge of \$153).

	W x D x H (in)	W x D x H (mm)	Code	Gr1 (\$)	Gr2 (\$)	Gr3 (\$)
Fabric acoustical panels, 24 3/4" H glass segment, powered	<i>Panel includes the tempered glass segment, in-line junction connectors, top trim, 2 covers with cut-outs and knock-out communication plates for the raceway, the electric system and the in-line power connector. To be ordered separately: duplex receptacles KER - - - -; refer to pages 29 and 30.</i>					
	24 x 2 x 54 3/8	610 x 51 x 1386	KPHAG-5424- P-	1,476	1,545	1,628
	30 x 2 x 54 3/8	762 x 51 x 1386	KPHAG-5430- P-	1,616	1,685	1,768
	36 x 2 x 54 3/8	914 x 51 x 1386	KPHAG-5436- P-	1,761	1,831	1,915
	42 x 2 x 54 3/8	1067 x 51 x 1386	KPHAG-5442- P-	1,896	1,966	2,049
	48 x 2 x 54 3/8	1219 x 51 x 1386	KPHAG-5448- P-	2,049	2,117	2,201
	60 x 2 x 54 3/8	1524 x 51 x 1386	KPHAG-5460- P-	2,360	2,430	2,513
	24 x 2 x 66 7/8	610 x 51 x 1700	KPHAG-6624- P-	1,520	1,591	1,673
	30 x 2 x 66 7/8	762 x 51 x 1700	KPHAG-6630- P-	1,673	1,743	1,826
	36 x 2 x 66 7/8	914 x 51 x 1700	KPHAG-6636- P-	1,819	1,889	1,972

At the end of the product code add, in this order: trim color, upholstery for sides A/B, clear (CG) or frosted (TG) finish for tempered glass (TG, surcharge of \$153).

42 x 2 x 66 7/8	1067 x 51 x 1700	KPHAG-6642- P-	1,958	2,029	2,111
48 x 2 x 66 7/8	1219 x 51 x 1700	KPHAG-6648- P-	2,125	2,193	2,278
60 x 2 x 66 7/8	1524 x 51 x 1700	KPHAG-6660- P-	2,442	2,513	2,595

Specify 3-circuit or 4-circuit system (surcharge of \$140 for 4-circuit). At the end of the product code add, in this order: trim color, upholstery for sides A/B, clear (CG) or frosted (TG) finish for tempered glass (TG, surcharge of \$153).

	W x D x H (in)	W x D x H (mm)	Code	Gr1 (\$)	Gr2 (\$)	Gr3 (\$)
Laminate panels, 24 3/4" H glass segment, non-powered	<i>Panel includes the tempered glass segment, in-line junction connectors, top trim, and 2 covers with no cut-outs for raceway.</i>					
	24 x 2 x 54 3/8	610 x 51 x 1386	KPHLG-5424- NN-			1,839
	30 x 2 x 54 3/8	762 x 51 x 1386	KPHLG-5430- NN-			1,931
	36 x 2 x 54 3/8	914 x 51 x 1386	KPHLG-5436- NN-			2,047
	42 x 2 x 54 3/8	1067 x 51 x 1386	KPHLG-5442- NN-			2,279
	48 x 2 x 54 3/8	1219 x 51 x 1386	KPHLG-5448- NN-			2,399
	24 x 2 x 66 7/8	610 x 51 x 1700	KPHLG-6624- NN-			1,979
	30 x 2 x 66 7/8	762 x 51 x 1700	KPHLG-6630- NN-			2,079
	36 x 2 x 66 7/8	914 x 51 x 1700	KPHLG-6636- NN-			2,192
	42 x 2 x 66 7/8	1067 x 51 x 1700	KPHLG-6642- NN-			2,492

At the end of the product code add, in this order: trim color, HPL finishes for sides A/B, clear (CG) or frosted (TG) finish for tempered glass (TG, surcharge of \$153).

48 x 2 x 66 7/8	1219 x 51 x 1700	KPHLG-6648- NN-			2,612
-----------------	------------------	-----------------	--	--	-------

At the end of the product code add, in this order: trim color, HPL finishes for sides A/B, clear (CG) or frosted (TG) finish for tempered glass (TG, surcharge of \$153).

A combination of HPL finishes may be applied to each side of a panel.

	W x D x H (in)	W x D x H (mm)	Code	Gr1 (\$)	Gr2 (\$)	Gr3 (\$)
Laminate panels, 24 3/4" H glass segment, powered	<i>Panel includes the tempered glass segment, in-line junction connectors, top trim, 2 covers with cut-outs and knock-out communication plates for the raceway, the electric system and the in-line power connector. To be ordered separately: duplex receptacles KER - - - -; refer to pages 29 and 30.</i>					
	24 x 2 x 54 3/8	610 x 51 x 1386	KPHLG-5424- P-			1,985
	30 x 2 x 54 3/8	762 x 51 x 1386	KPHLG-5430- P-			2,127
	36 x 2 x 54 3/8	914 x 51 x 1386	KPHLG-5436- P-			2,260
	42 x 2 x 54 3/8	1067 x 51 x 1386	KPHLG-5442- P-			2,486
	48 x 2 x 54 3/8	1219 x 51 x 1386	KPHLG-5448- P-			2,619
	24 x 2 x 66 7/8	610 x 51 x 1700	KPHLG-6624- P-			2,127
	30 x 2 x 66 7/8	762 x 51 x 1700	KPHLG-6630- P-			2,265
	36 x 2 x 66 7/8	914 x 51 x 1700	KPHLG-6636- P-			2,399
	42 x 2 x 66 7/8	1067 x 51 x 1700	KPHLG-6642- P-			2,699

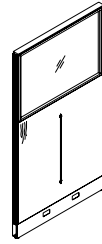

A combination of HPL finishes may be applied to each side of a panel.

48 x 2 x 66 7/8	1219 x 51 x 1700	KPHLG-6648- P-			2,833
-----------------	------------------	----------------	--	--	-------

Specify 3-circuit or 4-circuit system (surcharge of \$140 for 4-circuit). At the end of the product code add, in this order: trim color, HPL finishes for sides A/B, clear (CG) or frosted (TG) finish for tempered glass (TG, surcharge of \$153).

	W x D x H (in)	W x D x H (mm)	Code	Gr1 (\$)	Gr2 (\$)	Gr3 (\$)
Laminate/fabric combined panels, 24 3/4" H glass segment, non-powered	<i>Panel includes the tempered glass segment, in-line junction connectors, top trim, and 2 covers with no cut-outs for raceway.</i>					
	24 x 2 x 54 3/8	610 x 51 x 1386	KPHCG-5424- NN-	1,705	1,743	1,787
	30 x 2 x 54 3/8	762 x 51 x 1386	KPHCG-5430- NN-	1,813	1,850	1,896
	36 x 2 x 54 3/8	914 x 51 x 1386	KPHCG-5436- NN-	1,927	1,966	2,009
	42 x 2 x 54 3/8	1067 x 51 x 1386	KPHCG-5442- NN-	2,111	2,151	2,193
	48 x 2 x 54 3/8	1219 x 51 x 1386	KPHCG-5448- NN-	2,233	2,270	2,315
	24 x 2 x 66 7/8	610 x 51 x 1700	KPHCG-6624- NN-	1,831	1,870	1,915
	30 x 2 x 66 7/8	762 x 51 x 1700	KPHCG-6630- NN-	1,940	1,978	2,023
	36 x 2 x 66 7/8	914 x 51 x 1700	KPHCG-6636- NN-	2,060	2,100	2,142
	42 x 2 x 66 7/8	1067 x 51 x 1700	KPHCG-6642- NN-	2,270	2,309	2,354



A combination of HPL finishes may be applied to each side of a panel.

48 x 2 x 66 7/8	1219 x 51 x 1700	KPHCG-6648- NN-	2,391	2,430	2,473
-----------------	------------------	-----------------	-------	-------	-------

At the end of the product code add, in this order: trim color, HPL finish for side A, upholstery for side B, clear (CG) or frosted (TG) finish for tempered glass (TG, surcharge of \$153).

	W x D x H (in)	W x D x H (mm)	Code	Gr1 (\$)	Gr2 (\$)	Gr3 (\$)
Laminate/fabric combined panels, 24 3/4" H glass segment, powered	<i>Panel includes the tempered glass segment, in-line junction connectors, top trim, 2 covers with cut-outs and knock-out communication plates for the raceway, the electric system and the in-line power connector. To be ordered separately: duplex receptacles KER - - - -; refer to pages 29 and 30.</i>					
	24 x 2 x 54 3/8	610 x 51 x 1386	KPHCG-5424- P-	1,845	1,882	1,927
	30 x 2 x 54 3/8	762 x 51 x 1386	KPHCG-5430- P-	1,998	2,035	2,080
	36 x 2 x 54 3/8	914 x 51 x 1386	KPHCG-5436- P-	2,131	2,168	2,213
	42 x 2 x 54 3/8	1067 x 51 x 1386	KPHCG-5442- P-	2,303	2,341	2,385
	48 x 2 x 54 3/8	1219 x 51 x 1386	KPHCG-5448- P-	2,442	2,481	2,524
	24 x 2 x 66 7/8	610 x 51 x 1700	KPHCG-6624- P-	1,978	2,017	2,060
	30 x 2 x 66 7/8	762 x 51 x 1700	KPHCG-6630- P-	2,125	2,162	2,208
	36 x 2 x 66 7/8	914 x 51 x 1700	KPHCG-6636- P-	2,264	2,303	2,346
	42 x 2 x 66 7/8	1067 x 51 x 1700	KPHCG-6642- P-	2,467	2,506	2,550

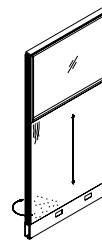

A combination of HPL finishes may be applied to each side of a panel.

48 x 2 x 66 7/8	1219 x 51 x 1700	KPHCG-6648- P-	2,601	2,640	2,684
-----------------	------------------	----------------	-------	-------	-------

Specify 3-circuit or 4-circuit system (surcharge of \$140 for 4-circuit). At the end of the product code add, in this order: trim color, HPL finish for side A, upholstery for side B, clear (CG) or frosted (TG) finish for tempered glass (TG, surcharge of \$153).

W x D x H (in)	W x D x H (mm)	Code	Gr1 (\$)	Gr2 (\$)	Gr3 (\$)
----------------	----------------	------	----------	----------	----------

SEGMENTED PANELS – 1 FABRIC UPPER SEGMENT

Fabric acoustical panels, 12 3/8" H fabric segment, non-powered

Panel includes in-line junction connectors, top trim and 2 covers with no cut-outs for raceway.

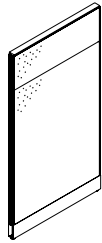

A combination of upholstery may be applied to each side of a panel. If they are of different grades, the cost of the upholstery will be based on the price of the higher grade for the base segment.

24 x 2 x 42 1/4	610 x 51 x 1072	KPQAA-4224-NN-___	1,043	1,113	1,195
30 x 2 x 42 1/4	762 x 51 x 1072	KPQAA-4230-NN-___	1,144	1,215	1,298
36 x 2 x 42 1/4	914 x 51 x 1072	KPQAA-4236-NN-___	1,260	1,329	1,412
42 x 2 x 42 1/4	1067 x 51 x 1072	KPQAA-4242-NN-___	1,386	1,456	1,540
48 x 2 x 42 1/4	1219 x 51 x 1072	KPQAA-4248-NN-___	1,520	1,591	1,673
60 x 2 x 42 1/4	1524 x 51 x 1072	KPQAA-4260-NN-___	1,749	1,819	1,901
24 x 2 x 54 3/8	610 x 51 x 1386	KPQAA-5424-NN-___	1,088	1,159	1,241
30 x 2 x 54 3/8	762 x 51 x 1386	KPQAA-5430-NN-___	1,195	1,266	1,349
36 x 2 x 54 3/8	914 x 51 x 1386	KPQAA-5436-NN-___	1,317	1,386	1,470
42 x 2 x 54 3/8	1067 x 51 x 1386	KPQAA-5442-NN-___	1,451	1,520	1,603
48 x 2 x 54 3/8	1219 x 51 x 1386	KPQAA-5448-NN-___	1,596	1,667	1,749
60 x 2 x 54 3/8	1524 x 51 x 1386	KPQAA-5460-NN-___	1,831	1,901	1,984
24 x 2 x 66 7/8	610 x 51 x 1700	KPQAA-6624-NN-___	1,119	1,190	1,272
30 x 2 x 66 7/8	762 x 51 x 1700	KPQAA-6630-NN-___	1,227	1,298	1,380
36 x 2 x 66 7/8	914 x 51 x 1700	KPQAA-6636-NN-___	1,354	1,425	1,507
42 x 2 x 66 7/8	1067 x 51 x 1700	KPQAA-6642-NN-___	1,488	1,558	1,642
48 x 2 x 66 7/8	1219 x 51 x 1700	KPQAA-6648-NN-___	1,634	1,705	1,787
60 x 2 x 66 7/8	1524 x 51 x 1700	KPQAA-6660-NN-___	1,876	1,947	2,029

At the end of the product code add, in this order: trim color, upholstery for sides A/B for the base segment, upholstery for sides A/B for the upper segment.

Fabric acoustical panels, 12 3/8" H fabric segment, powered

Panel includes in-line junction connectors, top trim, 2 covers with cut-outs and knock-out communication plates for the raceway, the electric system, and the in-line power connector. To be ordered separately: duplex receptacles KER -_-_-; refer to pages 29 and 30.

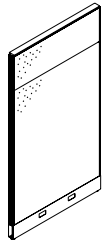

A combination of upholstery may be applied to each side of a panel. If they are of different grades, the cost of the upholstery will be based on the price of the higher grade for the base segment.

24 x 2 x 42 1/4	610 x 51 x 1072	KPQAA-4224- P-___	1,177	1,246	1,329
30 x 2 x 42 1/4	762 x 51 x 1072	KPQAA-4230- P-___	1,310	1,380	1,463
36 x 2 x 42 1/4	914 x 51 x 1072	KPQAA-4236- P-___	1,444	1,514	1,596
42 x 2 x 42 1/4	1067 x 51 x 1072	KPQAA-4242- P-___	1,571	1,642	1,724
48 x 2 x 42 1/4	1219 x 51 x 1072	KPQAA-4248- P-___	1,718	1,787	1,870
60 x 2 x 42 1/4	1524 x 51 x 1072	KPQAA-4260- P-___	2,003	2,074	2,157
24 x 2 x 54 3/8	610 x 51 x 1386	KPQAA-5424- P-___	1,227	1,298	1,380
30 x 2 x 54 3/8	762 x 51 x 1386	KPQAA-5430- P-___	1,368	1,437	1,520
36 x 2 x 54 3/8	914 x 51 x 1386	KPQAA-5436- P-___	1,507	1,577	1,659
42 x 2 x 54 3/8	1067 x 51 x 1386	KPQAA-5442- P-___	1,642	1,710	1,794
48 x 2 x 54 3/8	1219 x 51 x 1386	KPQAA-5448- P-___	1,787	1,857	1,940
60 x 2 x 54 3/8	1524 x 51 x 1386	KPQAA-5460- P-___	2,091	2,162	2,244
24 x 2 x 66 7/8	610 x 51 x 1700	KPQAA-6624- P-___	1,252	1,323	1,405
30 x 2 x 66 7/8	762 x 51 x 1700	KPQAA-6630- P-___	1,394	1,463	1,545
36 x 2 x 66 7/8	914 x 51 x 1700	KPQAA-6636- P-___	1,540	1,608	1,693
42 x 2 x 66 7/8	1067 x 51 x 1700	KPQAA-6642- P-___	1,673	1,743	1,826
48 x 2 x 66 7/8	1219 x 51 x 1700	KPQAA-6648- P-___	1,826	1,896	1,978
60 x 2 x 66 7/8	1524 x 51 x 1700	KPQAA-6660- P-___	2,131	2,201	2,283

Specify 3-circuit or 4-circuit system (surcharge of \$140 for 4-circuit). At the end of the product code add, in this order: trim color, upholstery for sides A/B for the base segment, upholstery for sides A/B for the upper segment.

Laminate panels, 12 3/8" H fabric segment, non-powered

Panel includes in-line junction connectors, top trim, and 2 covers with no cut-outs for the raceway.

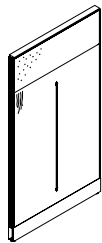

24 x 2 x 42 1/4	610 x 51 x 1072	KPQLA-4224-NN-___			1,465
30 x 2 x 42 1/4	762 x 51 x 1072	KPQLA-4230-NN-___			1,559
36 x 2 x 42 1/4	914 x 51 x 1072	KPQLA-4236-NN-___			1,659
42 x 2 x 42 1/4	1067 x 51 x 1072	KPQLA-4242-NN-___			1,873
48 x 2 x 42 1/4	1219 x 51 x 1072	KPQLA-4248-NN-___			1,979
24 x 2 x 54 3/8	610 x 51 x 1386	KPQLA-5424-NN-___			1,598
30 x 2 x 54 3/8	762 x 51 x 1386	KPQLA-5430-NN-___			1,693
36 x 2 x 54 3/8	914 x 51 x 1386	KPQLA-5436-NN-___			1,793
42 x 2 x 54 3/8	1067 x 51 x 1386	KPQLA-5442-NN-___			2,073
48 x 2 x 54 3/8	1219 x 51 x 1386	KPQLA-5448-NN-___			2,180

W x D x H (in)	W x D x H (mm)	Code	Price (\$)
----------------	----------------	------	------------

Laminate panels, 12 3/8" H fabric segment, non-powered (cont'd)

A combination of HPL finishes and upholstery may be applied to each side of a panel.

Laminate panels, 12 3/8" H fabric segment, powered

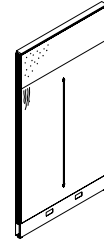

A combination of HPL finishes and upholstery may be applied to each side of a panel.

24 x 2 x 66 7/8	610 x 51 x 1700	KPQLA-6624-NN-___	1,733
30 x 2 x 66 7/8	762 x 51 x 1700	KPQLA-6630-NN-___	1,834
36 x 2 x 66 7/8	914 x 51 x 1700	KPQLA-6636-NN-___	1,931
42 x 2 x 66 7/8	1067 x 51 x 1700	KPQLA-6642-NN-___	2,272
48 x 2 x 66 7/8	1219 x 51 x 1700	KPQLA-6648-NN-___	2,380

At the end of the product code add, in this order: trim color, HPL finishes for sides A/B for the base segment, upholstery for sides A/B for the upper segment.

Panel includes in-line junction connectors, top trim, 2 covers with cut-outs and knock-out communication plates for the raceway, the electric system, and the in-line power connector. To be ordered separately: duplex receptacles KER -_-_-; refer to pages 29 and 30.

24 x 2 x 42 1/4	610 x 51 x 1072	KPQLA-4224- P-___	1,606
30 x 2 x 42 1/4	762 x 51 x 1072	KPQLA-4230- P-___	1,733
36 x 2 x 42 1/4	914 x 51 x 1072	KPQLA-4236- P-___	1,851
42 x 2 x 42 1/4	1067 x 51 x 1072	KPQLA-4242- P-___	2,065
48 x 2 x 42 1/4	1219 x 51 x 1072	KPQLA-4248- P-___	2,185
24 x 2 x 54 3/8	610 x 51 x 1386	KPQLA-5424- P-___	1,739
30 x 2 x 54 3/8	762 x 51 x 1386	KPQLA-5430- P-___	1,866
36 x 2 x 54 3/8	914 x 51 x 1386	KPQLA-5436- P-___	1,985
42 x 2 x 54 3/8	1067 x 51 x 1386	KPQLA-5442- P-___	2,265
48 x 2 x 54 3/8	1219 x 51 x 1386	KPQLA-5448- P-___	2,385
24 x 2 x 66 7/8	610 x 51 x 1700	KPQLA-6624- P-___	1,873
30 x 2 x 66 7/8	762 x 51 x 1700	KPQLA-6630- P-___	2,006
36 x 2 x 66 7/8	914 x 51 x 1700	KPQLA-6636- P-___	2,127
42 x 2 x 66 7/8	1067 x 51 x 1700	KPQLA-6642- P-___	2,465
48 x 2 x 66 7/8	1219 x 51 x 1700	KPQLA-6648- P-___	2,585

Specify 3-circuit or 4-circuit system (surcharge of \$140 for 4-circuit). At the end of the product code add, in this order: trim color, HPL finishes for sides A/B for the base segment, upholstery for sides A/B for the upper segment.

Fabric acoustical panels, 24 3/4" H fabric segment, non-powered

Panel includes in-line junction connectors, top trim, and 2 covers with no cut-outs for the raceway.

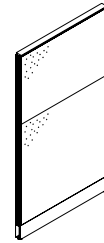

A combination of upholstery may be applied to each side of a panel. If they are of different grades, the cost of the upholstery will be based on the price of the higher grade for the base segment.

W x D x H (in)	W x D x H (mm)	Code	Gr1	Gr2	Gr3
24 x 2 x 54 3/8	610 x 51 x 1386	KPHAA-5424-NN-___	1,082	1,151	1,234
30 x 2 x 54 3/8	762 x 51 x 1386	KPHAA-5430-NN-___	1,190	1,260	1,343
36 x 2 x 54 3/8	914 x 51 x 1386	KPHAA-5436-NN-___	1,310	1,380	1,463
42 x 2 x 54 3/8	1067 x 51 x 1386	KPHAA-5442-NN-___	1,437	1,507	1,591
48 x 2 x 54 3/8	1219 x 51 x 1386	KPHAA-5448-NN-___	1,584	1,654	1,736
60 x 2 x 54 3/8	1524 x 51 x 1386	KPHAA-5460-NN-___	1,813	1,882	1,966
24 x 2 x 66 7/8	610 x 51 x 1700	KPHAA-6624-NN-___	1,125	1,195	1,278
30 x 2 x 66 7/8	762 x 51 x 1700	KPHAA-6630-NN-___	1,246	1,317	1,400
36 x 2 x 66 7/8	914 x 51 x 1700	KPHAA-6636-NN-___	1,368	1,437	1,520
42 x 2 x 66 7/8	1067 x 51 x 1700	KPHAA-6642-NN-___	1,507	1,577	1,659
48 x 2 x 66 7/8	1219 x 51 x 1700	KPHAA-6648-NN-___	1,654	1,724	1,806
60 x 2 x 66 7/8	1524 x 51 x 1700	KPHAA-6660-NN-___	1,896	1,966	2,049

At the end of the product code add, in this order: trim color, upholstery for sides A/B for the base segment, upholstery for sides A/B for the upper segment.

Fabric acoustical panels, 24 3/4" H fabric segment, powered

Panel includes in-line junction connectors, top trim, 2 covers with cut-outs and knock-out communication plates for the raceway, the electric system, and the in-line power connector. To be ordered separately: duplex receptacles KER -_-_-; refer to pages 29 and 30.

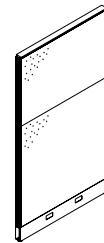

24 x 2 x 54 3/8	610 x 51 x 1386	KPHAA-5424- P-___	1,215	1,285	1,368
30 x 2 x 54 3/8	762 x 51 x 1386	KPHAA-5430- P-___	1,361	1,431	1,514
36 x 2 x 54 3/8	914 x 51 x 1386	KPHAA-5436- P-___	1,494	1,565	1,647
42 x 2 x 54 3/8	1067 x 51 x 1386	KPHAA-5442- P-___	1,628	1,698	1,780
48 x 2 x 54 3/8	1219 x 51 x 1386	KPHAA-5448- P-___	1,775	1,845	1,927
60 x 2 x 54 3/8	1524 x 51 x 1386	KPHAA-5460- P-___	2,074	2,142	2,227
24 x 2 x 66 7/8	610 x 51 x 1700	KPHAA-6624- P-___	1,266	1,335	1,419
30 x 2 x 66 7/8	762 x 51 x 1700	KPHAA-6630- P-___	1,412	1,482	1,565

	W x D x H (in)	W x D x H (mm)	Code	Gr1 (\$)	Gr2 (\$)	Gr3 (\$)
Fabric acoustical panels, 24 3/4" H fabric segment, powered (cont'd)	36 x 2 x 66 7/8	914 x 51 x 1700	KPHAA-6636- P-	1,558	1,628	1,710
	42 x 2 x 66 7/8	1067 x 51 x 1700	KPHAA-6642- P-	1,693	1,761	1,845
	48 x 2 x 66 7/8	1219 x 51 x 1700	KPHAA-6648- P-	1,850	1,921	2,003
	60 x 2 x 66 7/8	1524 x 51 x 1700	KPHAA-6660- P-	2,157	2,227	2,309

A combination of upholstery may be applied to each side of a panel. If they are of different grades, the cost of the upholstery will be based on the price of the higher grade for the base segment.

Specify 3-circuit or 4-circuit system (surcharge of \$140 for 4-circuit). At the end of the product code add, in this order: trim color, HPL finishes for sides A/B for the base segment, upholstery for sides A/B for the upper segment.

Laminate panels, 24 3/4" H fabric segment, non-powered *Panel includes in-line junction connectors, top trim, 2 covers with no cut-outs for the raceway.*

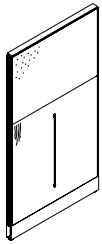

A combination of HPL finishes and upholstery may be applied to each side of a panel.

	W x D x H (in)	W x D x H (mm)	Code	Price (\$)
Laminate panels, 24 3/4" H fabric segment, non-powered	24 x 2 x 54 3/8	610 x 51 x 1386	KPHLA-5424-NN-	1,579
	30 x 2 x 54 3/8	762 x 51 x 1386	KPHLA-5430-NN-	1,686
	36 x 2 x 54 3/8	914 x 51 x 1386	KPHLA-5436-NN-	1,799
	42 x 2 x 54 3/8	1067 x 51 x 1386	KPHLA-5442-NN-	2,020
	48 x 2 x 54 3/8	1219 x 51 x 1386	KPHLA-5448-NN-	2,146
	24 x 2 x 66 7/8	610 x 51 x 1700	KPHLA-6624-NN-	1,719
	30 x 2 x 66 7/8	762 x 51 x 1700	KPHLA-6630-NN-	1,826
	36 x 2 x 66 7/8	914 x 51 x 1700	KPHLA-6636-NN-	1,940
	42 x 2 x 66 7/8	1067 x 51 x 1700	KPHLA-6642-NN-	2,233
	48 x 2 x 66 7/8	1219 x 51 x 1700	KPHLA-6648-NN-	2,359

At the end of the product code add, in this order: trim color, HPL finishes for sides A/B for the base segment, upholstery for sides A/B for the upper segment.

Laminate panels, 24 3/4" H fabric segment, powered *Panel includes in-line junction connectors, top trim, 2 covers with cut-outs and knock-out communication plates for the raceway, the electric system, and the in-line power connector. To be ordered separately: duplex receptacles KER - - - -; refer to pages 29 and 30.*

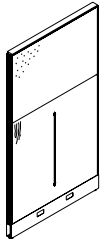

A combination of HPL finishes and upholstery may be applied to each side of a panel.

	W x D x H (in)	W x D x H (mm)	Code	Price (\$)
Laminate panels, 24 3/4" H fabric segment, powered	24 x 2 x 54 3/8	610 x 51 x 1386	KPHLA-5424- P-	1,726
	30 x 2 x 54 3/8	762 x 51 x 1386	KPHLA-5430- P-	1,873
	36 x 2 x 54 3/8	914 x 51 x 1386	KPHLA-5436- P-	1,999
	42 x 2 x 54 3/8	1067 x 51 x 1386	KPHLA-5442- P-	2,233
	48 x 2 x 54 3/8	1219 x 51 x 1386	KPHLA-5448- P-	2,359
	24 x 2 x 66 7/8	610 x 51 x 1700	KPHLA-6624- P-	1,866
	30 x 2 x 66 7/8	762 x 51 x 1700	KPHLA-6630- P-	2,011
	36 x 2 x 66 7/8	914 x 51 x 1700	KPHLA-6636- P-	2,139
	42 x 2 x 66 7/8	1067 x 51 x 1700	KPHLA-6642- P-	2,439
	48 x 2 x 66 7/8	1219 x 51 x 1700	KPHLA-6648- P-	2,566

Specify 3-circuit or 4-circuit system (surcharge of \$140 for 4-circuit). At the end of the product code add, in this order: trim color, HPL finishes for sides A/B for the base segment, upholstery for sides A/B for the upper segment.

SEGMENTED PANELS – 1 LAMINATE UPPER SEGMENT

Laminate panels, 12 3/8" H laminate segment, non-powered *Panel includes in-line junction connectors, top trim, and 2 covers with no cut-outs for the raceway.*

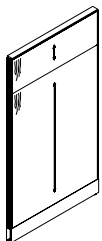

	W x D x H (in)	W x D x H (mm)	Code	Price (\$)
Laminate panels, 12 3/8" H laminate segment, non-powered	24 x 2 x 42 1/4	610 x 51 x 1072	KPQLL-4224-NN-	1,639
	30 x 2 x 42 1/4	762 x 51 x 1072	KPQLL-4230-NN-	1,726
	36 x 2 x 42 1/4	914 x 51 x 1072	KPQLL-4236-NN-	1,813
	42 x 2 x 42 1/4	1067 x 51 x 1072	KPQLL-4242-NN-	2,139
	48 x 2 x 42 1/4	1219 x 51 x 1072	KPQLL-4248-NN-	2,219
	24 x 2 x 54 3/8	610 x 51 x 1386	KPQLL-5424-NN-	1,826
	30 x 2 x 54 3/8	762 x 51 x 1386	KPQLL-5430-NN-	1,919
	36 x 2 x 54 3/8	914 x 51 x 1386	KPQLL-5436-NN-	2,006
	42 x 2 x 54 3/8	1067 x 51 x 1386	KPQLL-5442-NN-	2,419
	48 x 2 x 54 3/8	1219 x 51 x 1386	KPQLL-5448-NN-	2,499

	W x D x H (in)	W x D x H (mm)	Code	Price (\$)
Laminate panels, 12 3/8" H laminate segment, non-powered (cont'd)	24 x 2 x 66 7/8	610 x 51 x 1700	KPQLL-6624-NN-	2,011
	30 x 2 x 66 7/8	762 x 51 x 1700	KPQLL-6630-NN-	2,106
	36 x 2 x 66 7/8	914 x 51 x 1700	KPQLL-6636-NN-	2,199
	42 x 2 x 66 7/8	1067 x 51 x 1700	KPQLL-6642-NN-	2,685
	48 x 2 x 66 7/8	1219 x 51 x 1700	KPQLL-6648-NN-	2,779

A combination of HPL finishes may be applied to each side of a panel.

At the end of the product code add, in this order: trim color, HPL finishes for sides A/B for the base segment, HPL finishes for sides A/B for the upper segment.

Laminate panels, 12 3/8" H laminate segment, powered *Panel includes in-line junction connectors, top trim, 2 covers with cut-outs and knock-out communication plates for the raceway, the electric system, and the in-line power connector. To be ordered separately: duplex receptacles KER - - - -; refer to pages 29 and 30.*

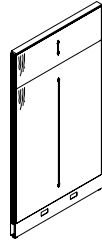

A combination of HPL finishes may be applied to each side of a panel.

	W x D x H (in)	W x D x H (mm)	Code	Price (\$)
Laminate panels, 12 3/8" H laminate segment, powered	24 x 2 x 42 1/4	610 x 51 x 1072	KPQLL-4224- P-	1,839
	30 x 2 x 42 1/4	762 x 51 x 1072	KPQLL-4230- P-	1,967
	36 x 2 x 42 1/4	914 x 51 x 1072	KPQLL-4236- P-	2,079
	42 x 2 x 42 1/4	1067 x 51 x 1072	KPQLL-4242- P-	2,406
	48 x 2 x 42 1/4	1219 x 51 x 1072	KPQLL-4248- P-	2,513
	24 x 2 x 54 3/8	610 x 51 x 1386	KPQLL-5424- P-	2,026
	30 x 2 x 54 3/8	762 x 51 x 1386	KPQLL-5430- P-	2,166
	36 x 2 x 54 3/8	914 x 51 x 1386	KPQLL-5436- P-	2,279
	42 x 2 x 54 3/8	1067 x 51 x 1386	KPQLL-5442- P-	2,685
	48 x 2 x 54 3/8	1219 x 51 x 1386	KPQLL-5448- P-	2,792
24 x 2 x 66 7/8	610 x 51 x 1700	KPQLL-6624- P-	2,212	
30 x 2 x 66 7/8	762 x 51 x 1700	KPQLL-6630- P-	2,352	
36 x 2 x 66 7/8	914 x 51 x 1700	KPQLL-6636- P-	2,472	
42 x 2 x 66 7/8	1067 x 51 x 1700	KPQLL-6642- P-	2,958	
48 x 2 x 66 7/8	1219 x 51 x 1700	KPQLL-6648- P-	3,072	

Specify 3-circuit or 4-circuit system (surcharge of \$140 for 4-circuit). At the end of the product code add, in this order: trim color, HPL finishes for sides A/B for the base segment, HPL finishes for sides A/B for the upper segment.

Laminate panels, 24 3/4" H laminate segment, non-powered *Panel includes in-line junction connectors, top trim, and 2 covers with no cut-outs for the raceway.*

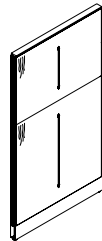

A combination of HPL finishes may be applied to each side of a panel.

	W x D x H (in)	W x D x H (mm)	Code	Price (\$)
Laminate panels, 24 3/4" H laminate segment, non-powered	24 x 2 x 54 3/8	610 x 51 x 1386	KPHLL-5424-NN-	1,851
	30 x 2 x 54 3/8	762 x 51 x 1386	KPHLL-5430-NN-	1,952
	36 x 2 x 54 3/8	914 x 51 x 1386	KPHLL-5436-NN-	2,032
	42 x 2 x 54 3/8	1067 x 51 x 1386	KPHLL-5442-NN-	2,452
	48 x 2 x 54 3/8	1219 x 51 x 1386	KPHLL-5448-NN-	2,540
	24 x 2 x 66 7/8	610 x 51 x 1700	KPHLL-6624-NN-	2,052
	30 x 2 x 66 7/8	762 x 51 x 1700	KPHLL-6630-NN-	2,139
	36 x 2 x 66 7/8	914 x 51 x 1700	KPHLL-6636-NN-	2,233
	42 x 2 x 66 7/8	1067 x 51 x 1700	KPHLL-6642-NN-	2,726
	48 x 2 x 66 7/8	1219 x 51 x 1700	KPHLL-6648-NN-	2,818

At the end of the product code add, in this order: trim color, HPL finishes for sides A/B for the base segment, HPL finishes for sides A/B for the upper segment.

Laminate panels, 24 3/4" H laminate segment, powered *Panel includes in-line junction connectors, top trim, 2 covers with cut-outs and knock-out communication plates for the raceway, the electric system, and the in-line power connector. To be ordered separately: duplex receptacles KER - - - -; refer to pages 29 and 30.*

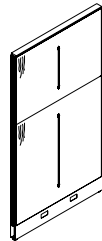

A combination of HPL finishes may be applied to each side of a panel.

	W x D x H (in)	W x D x H (mm)	Code	Price (\$)
Laminate panels, 24 3/4" H laminate segment, powered	24 x 2 x 54 3/8	610 x 51 x 1386	KPHLL-5424- P-	2,052
	30 x 2 x 54 3/8	762 x 51 x 1386	KPHLL-5430- P-	2,192
	36 x 2 x 54 3/8	914 x 51 x 1386	KPHLL-5436- P-	2,305
	42 x 2 x 54 3/8	1067 x 51 x 1386	KPHLL-5442- P-	2,726
	48 x 2 x 54 3/8	1219 x 51 x 1386	KPHLL-5448- P-	2,833
	24 x 2 x 66 7/8	610 x 51 x 1700	KPHLL-6624- P-	2,252
	30 x 2 x 66 7/8	762 x 51 x 1700	KPHLL-6630- P-	2,385
	36 x 2 x 66 7/8	914 x 51 x 1700	KPHLL-6636- P-	2,505
	42 x 2 x 66 7/8	1067 x 51 x 1700	KPHLL-6642- P-	2,998
	48 x 2 x 66 7/8	1219 x 51 x 1700	KPHLL-6648- P-	3,112

Specify 3-circuit or 4-circuit system (surcharge of \$140 for 4-circuit). At the end of the product code add, in this order: trim color, HPL finishes for sides A/B for the base segment, HPL finishes for sides A/B for the upper segment.

W x D x H (in)	W x D x H (mm)	Code	Gr1 (\$)	Gr2 (\$)	Gr3 (\$)
----------------	----------------	------	----------	----------	----------

SEGMENTED PANELS – FABRIC AND GLASS UPPER SEGMENTS

Fabric acoustical panels, 12 3/8" H fabric segment, 12 3/8" H glass segment, non-powered

Panel includes the tempered glass segment, in-line junction connectors, top trim, and 2 covers with no cut-outs for raceway.

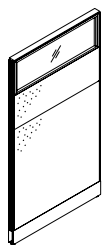

A combination of upholsteries may be applied to each side of a panel. If they are of different grades, the cost of the upholstery will be based on the price of the higher grade for the base segment.

24 x 2 x 54 3/8	610 x 51 x 1386	KPQAAG-5424-NN	1,718	1,787	1,870
30 x 2 x 54 3/8	762 x 51 x 1386	KPQAAG-5430-NN	1,864	1,934	2,017
36 x 2 x 54 3/8	914 x 51 x 1386	KPQAAG-5436-NN	2,035	2,106	2,188
42 x 2 x 54 3/8	1067 x 51 x 1386	KPQAAG-5442-NN	2,213	2,283	2,365
48 x 2 x 54 3/8	1219 x 51 x 1386	KPQAAG-5448-NN	2,411	2,481	2,564
60 x 2 x 54 3/8	1524 x 51 x 1386	KPQAAG-5460-NN	2,735	2,805	2,888
24 x 2 x 66 7/8	610 x 51 x 1700	KPQAAG-6624-NN	1,768	1,838	1,921
30 x 2 x 66 7/8	762 x 51 x 1700	KPQAAG-6630-NN	1,921	1,991	2,074
36 x 2 x 66 7/8	914 x 51 x 1700	KPQAAG-6636-NN	2,091	2,162	2,244
42 x 2 x 66 7/8	1067 x 51 x 1700	KPQAAG-6642-NN	2,283	2,354	2,436
48 x 2 x 66 7/8	1219 x 51 x 1700	KPQAAG-6648-NN	2,487	2,557	2,640
60 x 2 x 66 7/8	1524 x 51 x 1700	KPQAAG-6660-NN	2,817	2,888	2,970

At the end of the product code add, in this order: trim color, upholstery for sides A/B for the base segment, upholstery for sides A/B for the middle segment, clear (CG) or frosted (TG) finish for tempered glass (TG, surcharge of \$63).

Fabric acoustical panels, 12 3/8" H fabric segment, 12 3/8" H glass segment, powered

Panel includes the tempered glass segment, in-line junction connectors, top trim, 2 covers with cut-outs and knock-out communication plates for the raceway, the electric system and the in-line power connector. To be ordered separately: duplex receptacles KER - - - -; refer to pages 29 and 30.

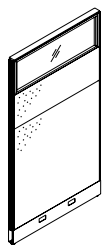

A combination of upholsteries may be applied to each side of a panel. If they are of different grades, the cost of the upholstery will be based on the price of the higher grade for the base segment.

24 x 2 x 54 3/8	610 x 51 x 1386	KPQAAG-5424- P-	1,857	1,927	2,009
30 x 2 x 54 3/8	762 x 51 x 1386	KPQAAG-5430- P-	2,035	2,106	2,188
36 x 2 x 54 3/8	914 x 51 x 1386	KPQAAG-5436- P-	2,219	2,290	2,372
42 x 2 x 54 3/8	1067 x 51 x 1386	KPQAAG-5442- P-	2,397	2,467	2,550
48 x 2 x 54 3/8	1219 x 51 x 1386	KPQAAG-5448- P-	2,607	2,677	2,760
60 x 2 x 54 3/8	1524 x 51 x 1386	KPQAAG-5460- P-	2,996	3,066	3,148
24 x 2 x 66 7/8	610 x 51 x 1700	KPQAAG-6624- P-	1,901	1,972	2,055
30 x 2 x 66 7/8	762 x 51 x 1700	KPQAAG-6630- P-	2,086	2,157	2,239
36 x 2 x 66 7/8	914 x 51 x 1700	KPQAAG-6636- P-	2,278	2,346	2,430
42 x 2 x 66 7/8	1067 x 51 x 1700	KPQAAG-6642- P-	2,467	2,538	2,621
48 x 2 x 66 7/8	1219 x 51 x 1700	KPQAAG-6648- P-	2,677	2,748	2,830
60 x 2 x 66 7/8	1524 x 51 x 1700	KPQAAG-6660- P-	3,078	3,148	3,230

Specify 3-circuit or 4-circuit system (surcharge of \$140 for 4-circuit). At the end of the product code add, in this order: trim color, upholstery for sides A/B of the base segment, upholstery for sides A/B of the middle segment, clear (CG) or frosted (TG) finish for tempered glass (TG, surcharge of \$63).

Laminate panels, 12 3/8" H fabric segment, 12 3/8" H glass segment, non-powered

Panel includes the tempered glass segment, in-line junction connectors, top trim, and 2 covers with no cut-outs for the raceway.

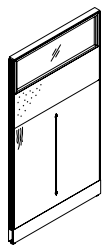

A combination of HPL finishes and upholstery may be applied to each side of a panel.

24 x 2 x 54 3/8	610 x 51 x 1386	KPQLAG-5424-NN			\$ 2,172
30 x 2 x 54 3/8	762 x 51 x 1386	KPQLAG-5430-NN			2,313
36 x 2 x 54 3/8	914 x 51 x 1386	KPQLAG-5436-NN			2,472
42 x 2 x 54 3/8	1067 x 51 x 1386	KPQLAG-5442-NN			2,738
48 x 2 x 54 3/8	1219 x 51 x 1386	KPQLAG-5448-NN			2,912
24 x 2 x 66 7/8	610 x 51 x 1700	KPQLAG-6624-NN			2,305
30 x 2 x 66 7/8	762 x 51 x 1700	KPQLAG-6630-NN			2,445
36 x 2 x 66 7/8	914 x 51 x 1700	KPQLAG-6636-NN			2,605
42 x 2 x 66 7/8	1067 x 51 x 1700	KPQLAG-6642-NN			2,939
48 x 2 x 66 7/8	1219 x 51 x 1700	KPQLAG-6648-NN			3,112

At the end of the product code add, in this order: trim color, HPL finishes for sides A/B for the base segment, upholstery for sides A/B for the middle segment, clear (CG) or frosted (TG) finish for tempered glass (TG, surcharge of \$63).

W x D x H (in)	W x D x H (mm)	Code	Gr1 (\$)	Gr2 (\$)	Gr3 (\$)
----------------	----------------	------	----------	----------	----------

Laminate panels, 12 3/8" H fabric segment, 12 3/8" H glass segment, powered

Panel includes the tempered glass segment, in-line junction connectors, top trim, 2 covers with cut-outs and knock-out communication plates for the raceway, the electric system and the in-line power connector. To be ordered separately: duplex receptacles KER - - - -; refer to pages 29 and 30.

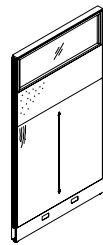

A combination of HPL finishes and upholstery may be applied to each side of a panel.

24 x 2 x 54 3/8	610 x 51 x 1386	KPQLAG-5424- P-			2,313
30 x 2 x 54 3/8	762 x 51 x 1386	KPQLAG-5430- P-			2,492
36 x 2 x 54 3/8	914 x 51 x 1386	KPQLAG-5436- P-			2,666
42 x 2 x 54 3/8	1067 x 51 x 1386	KPQLAG-5442- P-			2,939
48 x 2 x 54 3/8	1219 x 51 x 1386	KPQLAG-5448- P-			3,118
24 x 2 x 66 7/8	610 x 51 x 1700	KPQLAG-6624- P-			2,445
30 x 2 x 66 7/8	762 x 51 x 1700	KPQLAG-6630- P-			2,625
36 x 2 x 66 7/8	914 x 51 x 1700	KPQLAG-6636- P-			2,798
42 x 2 x 66 7/8	1067 x 51 x 1700	KPQLAG-6642- P-			3,139
48 x 2 x 66 7/8	1219 x 51 x 1700	KPQLAG-6648- P-			3,319

Specify 3-circuit or 4-circuit system (surcharge of \$140 for 4-circuit). At the end of the product code add, in this order: trim color, HPL finishes for sides A/B of the base segment, upholstery for sides A/B of the middle segment, clear (CG) or frosted (TG) finish for tempered glass (TG, surcharge of \$63).

SEGMENTED PANELS – 2 FABRIC UPPER SEGMENTS

Fabric acoustical panels, 2 fabric segments 12 3/8" H, non-powered

Panel includes in-line junction connectors, top trim, and 2 covers with no cut-outs for the raceway.

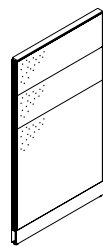

A combination of upholsteries may be applied to each side of a panel. If they are of different grades, the cost of the upholstery will be based on the price of the higher grade for the base segment.

W x D x H (in)	W x D x H (mm)	Code	Gr1 (\$)	Gr2 (\$)	Gr3 (\$)
24 x 2 x 54 3/8	610 x 51 x 1386	KPQAAA-5424-NN	1,507	1,577	1,659
30 x 2 x 54 3/8	762 x 51 x 1386	KPQAAA-5430-NN	1,647	1,718	1,800
36 x 2 x 54 3/8	914 x 51 x 1386	KPQAAA-5436-NN	1,819	1,889	1,972
42 x 2 x 54 3/8	1067 x 51 x 1386	KPQAAA-5442-NN	1,998	2,068	2,151
48 x 2 x 54 3/8	1219 x 51 x 1386	KPQAAA-5448-NN	2,201	2,270	2,354
60 x 2 x 54 3/8	1524 x 51 x 1386	KPQAAA-5460-NN	2,524	2,595	2,677
24 x 2 x 66 7/8	610 x 51 x 1700	KPQAAA-6624-NN	1,552	1,622	1,705
30 x 2 x 66 7/8	762 x 51 x 1700	KPQAAA-6630-NN	1,705	1,775	1,857
36 x 2 x 66 7/8	914 x 51 x 1700	KPQAAA-6636-NN	1,876	1,947	2,029
42 x 2 x 66 7/8	1067 x 51 x 1700	KPQAAA-6642-NN	2,066	2,137	2,219
48 x 2 x 66 7/8	1219 x 51 x 1700	KPQAAA-6648-NN	2,270	2,341	2,423
60 x 2 x 66 7/8	1524 x 51 x 1700	KPQAAA-6660-NN	2,607	2,677	2,760

At the end of the product code add, in this order: trim color, upholstery for sides A/B for the base segment, upholstery for sides A/B for the middle segment, upholstery for sides A/B for the upper segment.

Fabric acoustical panels, 2 fabric segments 12 3/8" H, powered

Panel includes in-line junction connectors, top trim, 2 covers with cut-outs for the raceway, the electric system, and the in-line power connector. To be ordered separately: duplex receptacles KER - - - -; refer to pages 29 and 30.

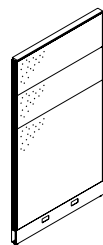

A combination of upholsteries may be applied to each side of a panel. If they are of different grades, the cost of the upholstery will be based on the price of the higher grade for the base segment.

24 x 2 x 54 3/8	610 x 51 x 1386	KPQAAA-5424- P-	1,642	1,710	1,794
30 x 2 x 54 3/8	762 x 51 x 1386	KPQAAA-5430- P-	1,819	1,889	1,972
36 x 2 x 54 3/8	914 x 51 x 1386	KPQAAA-5436- P-	2,003	2,074	2,157
42 x 2 x 54 3/8	1067 x 51 x 1386	KPQAAA-5442- P-	2,188	2,259	2,341
48 x 2 x 54 3/8	1219 x 51 x 1386	KPQAAA-5448- P-	2,391	2,462	2,544
60 x 2 x 54 3/8	1524 x 51 x 1386	KPQAAA-5460- P-	2,779	2,849	2,931
24 x 2 x 66 7/8	610 x 51 x 1700	KPQAAA-6624- P-	1,685	1,756	1,838
30 x 2 x 66 7/8	762 x 51 x 1700	KPQAAA-6630- P-	1,870	1,940	2,023
36 x 2 x 66 7/8	914 x 51 x 1700	KPQAAA-6636- P-	2,066	2,137	2,219
42 x 2 x 66 7/8	1067 x 51 x 1700	KPQAAA-6642- P-	2,252	2,321	2,404
48 x 2 x 66 7/8	1219 x 51 x 1700	KPQAAA-6648- P-	2,467	2,538	2,621
60 x 2 x 66 7/8	1524 x 51 x 1700	KPQAAA-6660- P-	2,868	2,939	3,021

Specify 3-circuit or 4-circuit system (surcharge of \$140 for 4-circuit). At the end of the product code add, in this order: trim color, upholstery for sides A/B of the base segment, upholstery for sides A/B of the middle segment, upholstery for sides A/B of the upper segment.

W x D x H (in)	W x D x H (mm)	Code	Price (\$)
Laminate panels, 2 fabric segments 12 3/8" H, non-powered			
<i>Panel includes in-line junction connectors, top trim, and 2 covers with no cut-outs for the raceway.</i>			
24 x 2 x 54 3/8	610 x 51 x 1386	KPQLAA-5424-NN-__	1,952
30 x 2 x 54 3/8	762 x 51 x 1386	KPQLAA-5430-NN-__	2,086
36 x 2 x 54 3/8	914 x 51 x 1386	KPQLAA-5436-NN-__	2,245
42 x 2 x 54 3/8	1067 x 51 x 1386	KPQLAA-5442-NN-__	2,518
48 x 2 x 54 3/8	1219 x 51 x 1386	KPQLAA-5448-NN-__	2,693
24 x 2 x 66 7/8	610 x 51 x 1700	KPQLAA-6624-NN-__	2,086
30 x 2 x 66 7/8	762 x 51 x 1700	KPQLAA-6630-NN-__	2,219
36 x 2 x 66 7/8	914 x 51 x 1700	KPQLAA-6636-NN-__	2,380
42 x 2 x 66 7/8	1067 x 51 x 1700	KPQLAA-6642-NN-__	2,719
48 x 2 x 66 7/8	1219 x 51 x 1700	KPQLAA-6648-NN-__	2,891

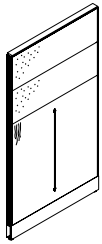

A combination of HPL finishes and upholstery may be applied to each side of a panel.

W x D x H (in)	W x D x H (mm)	Code	Price (\$)
Laminate panels, 2 fabric segments 12 3/8" H, powered			
<i>Panel includes in-line junction connectors, top trim, 2 covers with cut-outs for the raceway, the electric system, and the in-line power connector. To be ordered separately: duplex receptacles KER - - - ; refer to pages 29 and 30.</i>			
24 x 2 x 54 3/8	610 x 51 x 1386	KPQLAA-5424- P-__	2,091
30 x 2 x 54 3/8	762 x 51 x 1386	KPQLAA-5430- P-__	2,265
36 x 2 x 54 3/8	914 x 51 x 1386	KPQLAA-5436- P-__	2,439
42 x 2 x 54 3/8	1067 x 51 x 1386	KPQLAA-5442- P-__	2,712
48 x 2 x 54 3/8	1219 x 51 x 1386	KPQLAA-5448- P-__	2,891
24 x 2 x 66 7/8	610 x 51 x 1700	KPQLAA-6624- P-__	2,225
30 x 2 x 66 7/8	762 x 51 x 1700	KPQLAA-6630- P-__	2,399
36 x 2 x 66 7/8	914 x 51 x 1700	KPQLAA-6636- P-__	2,572
42 x 2 x 66 7/8	1067 x 51 x 1700	KPQLAA-6642- P-__	2,912
48 x 2 x 66 7/8	1219 x 51 x 1700	KPQLAA-6648- P-__	3,091

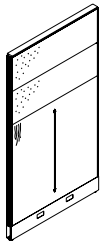

A combination of HPL finishes and upholstery may be applied to each side of a panel.

At the end of the product code add, in this order: trim color, HPL finishes for sides A/B for the base segment, upholstery for sides A/B for the middle segment, upholstery for sides A/B for the upper segment.

Specify 3-circuit or 4-circuit system (surcharge of \$140 for 4-circuit). At the end of the product code add, in this order: trim color, HPL finishes for sides A/B of the base segment, upholstery for sides A/B of the middle segment, upholstery for sides A/B of the upper segment.

LAMINATE GALLERY PANELS

Laminate gallery panels, end-of-run, single
Is installed at the end of a monolithic or segmented panel and serves as a return panel. Corner braces included to fasten to the front of a surface. Note: An end-of-run trim of variable height KVETS-__ is required if the monolithic or segmented panel is taller than the end panel; refer to page 28.

22 x 1 x 29 7/8	559 x 25 x 758	KPLES-3022-NN- -	528
26 x 1 x 29 7/8	660 x 25 x 758	KPLES-3026-NN- -	547
32 x 1 x 29 7/8	813 x 25 x 758	KPLES-3032-NN- -	566
38 x 1 x 29 7/8	965 x 25 x 758	KPLES-3038-NN- -	578
50 x 1 x 29 7/8	1270 x 25 x 758	KPLES-3050-NN- -	598
62 x 1 x 29 7/8	1575 x 25 x 758	KPLES-3062-NN- -	629
22 x 1 x 42 1/4	559 x 25 x 1072	KPLES-4222-NN- -	566
26 x 1 x 42 1/4	660 x 25 x 1072	KPLES-4226-NN- -	592
32 x 1 x 42 1/4	813 x 25 x 1072	KPLES-4232-NN- -	610
38 x 1 x 42 1/4	965 x 25 x 1072	KPLES-4238-NN- -	629
50 x 1 x 42 1/4	1270 x 25 x 1072	KPLES-4250-NN- -	655
62 x 1 x 42 1/4	1575 x 25 x 1072	KPLES-4262-NN- -	700
22 x 1 x 48 3/8	559 x 25 x 1229	KPLES-4822-NN- -	586
26 x 1 x 48 3/8	660 x 25 x 1229	KPLES-4826-NN- -	610
32 x 1 x 48 3/8	813 x 25 x 1229	KPLES-4832-NN- -	636
38 x 1 x 48 3/8	965 x 25 x 1229	KPLES-4838-NN- -	661
50 x 1 x 48 3/8	1270 x 25 x 1229	KPLES-4850-NN- -	686
62 x 1 x 48 3/8	1575 x 25 x 1229	KPLES-4862-NN- -	731
22 x 1 x 54 3/8	559 x 25 x 1386	KPLES-5422-NN- -	604
26 x 1 x 54 3/8	660 x 25 x 1386	KPLES-5426-NN- -	629
32 x 1 x 54 3/8	813 x 25 x 1386	KPLES-5432-NN- -	655
38 x 1 x 54 3/8	965 x 25 x 1386	KPLES-5438-NN- -	686
50 x 1 x 54 3/8	1270 x 25 x 1386	KPLES-5450-NN- -	712
62 x 1 x 54 3/8	1575 x 25 x 1386	KPLES-5462-NN- -	769

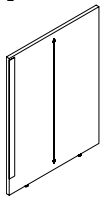
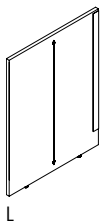

Contrary to the pictograms above, panels over 50" (1270 mm) W have a horizontal wood grain rather than a vertical one.

Specify if a left-side (L) or right-side (R) installation. At the end of the product code add, in this order: trim color, laminate finish.

W x D x H (in)	W x D x H (mm)	Code	Price (\$)
Laminate gallery panels with 6 1/8" H glass, end-of-run, single			
<i>Is installed at the end of a monolithic or segmented panel and serves as a return panel. Panel includes tempered glass screen and corner braces to fasten to the front of a surface. Note: An end-of-run trim of variable height KVETS-__ is required if the monolithic or segmented panel is taller than the end panel; refer to page 28.</i>			
<i>29 7/8" (758 mm) H panel with 6 1/8" (157 mm) H glass.</i>			
22 x 1 x 36	559 x 25 x 915	KPLESG-3022-06- -	828
26 x 1 x 36	660 x 25 x 915	KPLESG-3026-06- -	839
32 x 1 x 36	813 x 25 x 915	KPLESG-3032-06- -	859
38 x 1 x 36	965 x 25 x 915	KPLESG-3038-06- -	890
50 x 1 x 36	1270 x 25 x 915	KPLESG-3050-06- -	929
62 x 1 x 36	1575 x 25 x 915	KPLESG-3062-06- -	992
<i>42 1/4" (1072 mm) H panel with 6 1/8" (157 mm) H glass.</i>			
22 x 1 x 48 3/8	559 x 25 x 1229	KPLESG-4222-06- -	859
26 x 1 x 48 3/8	660 x 25 x 1229	KPLESG-4226-06- -	878
32 x 1 x 48 3/8	813 x 25 x 1229	KPLESG-4232-06- -	904
38 x 1 x 48 3/8	965 x 25 x 1229	KPLESG-4238-06- -	936
50 x 1 x 48 3/8	1270 x 25 x 1229	KPLESG-4250-06- -	980
62 x 1 x 48 3/8	1575 x 25 x 1229	KPLESG-4262-06- -	1,049
<i>48 3/8" (1229 mm) H panel with 6 1/8" (157 mm) H glass.</i>			
22 x 1 x 54 3/8	559 x 25 x 1386	KPLESG-4822-06- -	878
26 x 1 x 54 3/8	660 x 25 x 1386	KPLESG-4826-06- -	904
32 x 1 x 54 3/8	813 x 25 x 1386	KPLESG-4832-06- -	929
38 x 1 x 54 3/8	965 x 25 x 1386	KPLESG-4838-06- -	967
50 x 1 x 54 3/8	1270 x 25 x 1386	KPLESG-4850-06- -	1,018
62 x 1 x 54 3/8	1575 x 25 x 1386	KPLESG-4862-06- -	1,093

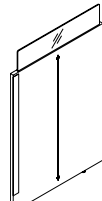
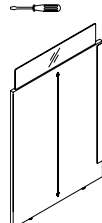

Contrary to the pictograms above, panels over 50" (1270 mm) W have a horizontal wood grain rather than a vertical one.

Laminate gallery panels with 12 3/8" H glass, end-of-run, single			
<i>Is installed at the end of a monolithic or segmented panel and serves as a return panel. Panel includes tempered glass screen and corner braces to fasten to the front of a surface. Note: An end-of-run trim of variable height KVETS-__ is required if the monolithic or segmented panel is taller than the end panel; refer to page 28.</i>			
<i>29 7/8" (758 mm) H panel with 12 3/8" (314 mm) H glass.</i>			
22 x 1 x 42 1/4	559 x 25 x 1072	KPLESG-3022-12- -	885
26 x 1 x 42 1/4	660 x 25 x 1072	KPLESG-3026-12- -	910
32 x 1 x 42 1/4	813 x 25 x 1072	KPLESG-3032-12- -	955
38 x 1 x 42 1/4	965 x 25 x 1072	KPLESG-3038-12- -	998
50 x 1 x 42 1/4	1270 x 25 x 1072	KPLESG-3050-12- -	1,062
62 x 1 x 42 1/4	1575 x 25 x 1072	KPLESG-3062-12- -	1,151
<i>42 1/4" (1072 mm) H panel with 12 3/8" (314 mm) H glass.</i>			
22 x 1 x 54 3/8	559 x 25 x 1386	KPLESG-4222-12- -	916
26 x 1 x 54 3/8	660 x 25 x 1386	KPLESG-4226-12- -	947
32 x 1 x 54 3/8	813 x 25 x 1386	KPLESG-4232-12- -	998
38 x 1 x 54 3/8	965 x 25 x 1386	KPLESG-4238-12- -	1,049
50 x 1 x 54 3/8	1270 x 25 x 1386	KPLESG-4250-12- -	1,119
62 x 1 x 54 3/8	1575 x 25 x 1386	KPLESG-4262-12- -	1,215

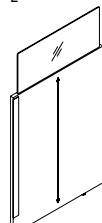
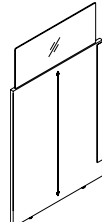

Contrary to the pictograms above, panels over 50" (1270 mm) W have a horizontal wood grain rather than a vertical one.

Specify if a left-side (L) or right-side (R) installation. At the end of the product code add, in this order: trim color, laminate finish, clear (CG) or frosted (TG) finish for tempered glass (TG, surcharge of \$108).

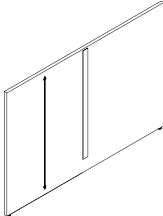
	W x D x H (in)	W x D x H (mm)	Code	Price (\$)
Laminate gallery panels, end-of-run, shared				
<i>Is installed at the end of a monolithic or segmented panel and serves as a return panels. Corner braces included to fasten to the front of a surface. Note: An end-of-run trim of variable height KVETS-__ is required if the monolithic or segmented panel is taller than the end panel; refer to page 28.</i>				
	42 x 1 x 29 ⁷ / ₈	1067 x 25 x 758	KPLED-3042-NN-__	694
	50 x 1 x 29 ⁷ / ₈	1270 x 25 x 758	KPLED-3050-NN-__	731
	62 x 1 x 29 ⁷ / ₈	1575 x 25 x 758	KPLED-3062-NN-__	763
	74 x 1 x 29 ⁷ / ₈	1879 x 25 x 758	KPLED-3074-NN-__	795
	98 x 1 x 29 ⁷ / ₈	2489 x 25 x 758	KPLED-3098-NN-__	834
	42 x 1 x 42 ¹ / ₄	1067 x 25 x 1072	KPLED-4242-NN-__	706
	50 x 1 x 42 ¹ / ₄	1270 x 25 x 1072	KPLED-4250-NN-__	751
	62 x 1 x 42 ¹ / ₄	1575 x 25 x 1072	KPLED-4262-NN-__	788
	74 x 1 x 42 ¹ / ₄	1879 x 25 x 1072	KPLED-4274-NN-__	828
	98 x 1 x 42 ¹ / ₄	2489 x 25 x 1072	KPLED-4298-NN-__	870
	42 x 1 x 48 ³ / ₈	1067 x 25 x 1229	KPLED-4842-NN-__	719
	50 x 1 x 48 ³ / ₈	1270 x 25 x 1229	KPLED-4850-NN-__	769
	62 x 1 x 48 ³ / ₈	1575 x 25 x 1229	KPLED-4862-NN-__	814
	74 x 1 x 48 ³ / ₈	1879 x 25 x 1229	KPLED-4874-NN-__	859
	98 x 1 x 48 ³ / ₈	2489 x 25 x 1229	KPLED-4898-NN-__	910
	42 x 1 x 54 ⁵ / ₈	1067 x 25 x 1386	KPLED-5442-NN-__	731
50 x 1 x 54 ⁵ / ₈	1270 x 25 x 1386	KPLED-5450-NN-__	788	
62 x 1 x 54 ⁵ / ₈	1575 x 25 x 1386	KPLED-5462-NN-__	839	
74 x 1 x 54 ⁵ / ₈	1879 x 25 x 1386	KPLED-5474-NN-__	890	
98 x 1 x 54 ⁵ / ₈	2489 x 25 x 1386	KPLED-5498-NN-__	947	
At the end of the product code add, in this order: trim color, laminate finish.				

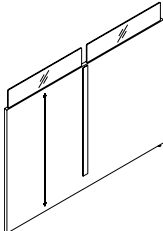
	W x D x H (in)	W x D x H (mm)	Code	Price (\$)
Laminate gallery panels with 6¹/₈" H glass, end-of-run, shared				
<i>Is installed at the end of a monolithic or segmented panel and serves as a return panels. Panel includes tempered glass screens and corner braces to fasten to the front of a surface. Note: An end-of-run trim of variable height KVETS-__ is required if the monolithic or segmented panel is taller than the end panel; refer to page 28.</i>				
	29 ⁷ / ₈ " (758 mm) H panel with 6 ¹ / ₈ " (157 mm) H glass.			
	42 x 1 x 36	1067 x 25 x 915	KPLEDG-3042-06-__	992
	50 x 1 x 36	1270 x 25 x 915	KPLEDG-3050-06-__	1,049
	62 x 1 x 36	1575 x 25 x 915	KPLEDG-3062-06-__	1,119
	74 x 1 x 36	1879 x 25 x 915	KPLEDG-3074-06-__	1,201
	98 x 1 x 36	2489 x 25 x 915	KPLEDG-3098-06-__	1,317
	42 ¹ / ₄ " (1072 mm) H panel with 6 ¹ / ₈ " (157 mm) H glass.			
	42 x 1 x 48 ³ / ₈	1067 x 25 x 1229	KPLEDG-4242-06-__	1,018
	50 x 1 x 48 ³ / ₈	1270 x 25 x 1229	KPLEDG-4250-06-__	1,093
	62 x 1 x 48 ³ / ₈	1575 x 25 x 1229	KPLEDG-4262-06-__	1,184
	74 x 1 x 48 ³ / ₈	1879 x 25 x 1229	KPLEDG-4274-06-__	1,285
	98 x 1 x 48 ³ / ₈	2489 x 25 x 1229	KPLEDG-4298-06-__	1,419
	48 ³ / ₈ " (1229 mm) H panel with 6 ¹ / ₈ " (157 mm) H glass.			
	42 x 1 x 54 ⁵ / ₈	1067 x 25 x 1386	KPLEDG-4842-06-__	1,043
	50 x 1 x 54 ⁵ / ₈	1270 x 25 x 1386	KPLEDG-4850-06-__	1,125
	62 x 1 x 54 ⁵ / ₈	1575 x 25 x 1386	KPLEDG-4862-06-__	1,221
74 x 1 x 54 ⁵ / ₈	1879 x 25 x 1386	KPLEDG-4874-06-__	1,329	
98 x 1 x 54 ⁵ / ₈	2489 x 25 x 1386	KPLEDG-4898-06-__	1,470	
At the end of the product code add, in this order: trim color, laminate finish, clear (CG) or frosted (TG) finish for tempered glass (TG, surcharge of \$63).				

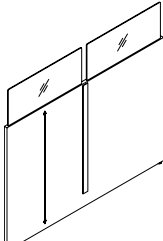
	W x D x H (in)	W x D x H (mm)	Code	Price (\$)
Laminate gallery panels with 12³/₈" H glass, end-of-run, shared				
<i>Is installed at the end of a monolithic or segmented panel and serves as a return panels. Panel includes tempered glass screens and corner braces to fasten to the front of a surface. Note: An end-of-run trim of variable height KVETS-__ is required if the monolithic or segmented panel is taller than the end panel; refer to page 28.</i>				
	29 ⁷ / ₈ " (758 mm) H panel with 12 ³ / ₈ " (314 mm) H glass.			
	42 x 1 x 42 ¹ / ₄	1067 x 25 x 1072	KPLEDG-3042-12-__	1,037
	50 x 1 x 42 ¹ / ₄	1270 x 25 x 1072	KPLEDG-3050-12-__	1,100
	62 x 1 x 42 ¹ / ₄	1575 x 25 x 1072	KPLEDG-3062-12-__	1,201
	74 x 1 x 42 ¹ / ₄	1879 x 25 x 1072	KPLEDG-3074-12-__	1,303
	98 x 1 x 42 ¹ / ₄	2489 x 25 x 1072	KPLEDG-3098-12-__	1,444
	42 ¹ / ₄ " (1072 mm) H panel with 12 ³ / ₈ " (314 mm) H glass.			
	42 x 1 x 54 ⁵ / ₈	1067 x 25 x 1386	KPLEDG-4242-12-__	1,062
	50 x 1 x 54 ⁵ / ₈	1270 x 25 x 1386	KPLEDG-4250-12-__	1,144

	W x D x H (in)	W x D x H (mm)	Code	Price (\$)
Laminate gallery panels with 12³/₈" H glass, end-of-run, shared (cont'd)				
62 x 1 x 54 ⁵ / ₈	1575 x 25 x 1386	KPLEDG-4262-12-__	1,266	
74 x 1 x 54 ⁵ / ₈	1879 x 25 x 1386	KPLEDG-4274-12-__	1,386	
98 x 1 x 54 ⁵ / ₈	2489 x 25 x 1386	KPLEDG-4298-12-__	1,545	
At the end of the product code add, in this order: trim color, laminate finish, clear (CG) or frosted (TG) finish for tempered glass (TG, surcharge of \$108).				

Contrary to the preceding pictogram, panels over 50" (1270 mm) W have a horizontal wood grain rather than a vertical one.

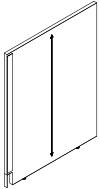
	W x D x H (in)	W x D x H (mm)	Code	Price (\$)	
Laminate gallery panels, intersection, single					
<i>Is installed between two monolithic or segmented panels and serves as a return panel. Corner braces included to fasten to the front of a surface. Note: Two end-of-run trims of variable height KVETS-__ are required if the monolithic or segmented panels are taller than the intersection panel; refer to page 28.</i>					
	22 x 1 x 29 ⁷ / ₈	559 x 25 x 758	KPLMS-3022-NN-__	675	
	26 x 1 x 29 ⁷ / ₈	660 x 25 x 758	KPLMS-3026-NN-__	694	
	32 x 1 x 29 ⁷ / ₈	813 x 25 x 758	KPLMS-3032-NN-__	712	
	38 x 1 x 29 ⁷ / ₈	965 x 25 x 758	KPLMS-3038-NN-__	731	
	50 x 1 x 29 ⁷ / ₈	1270 x 25 x 758	KPLMS-3050-NN-__	751	
	62 x 1 x 29 ⁷ / ₈	1575 x 25 x 758	KPLMS-3062-NN-__	769	
	22 x 1 x 42 ¹ / ₄	559 x 25 x 1072	KPLMS-4222-NN-__	719	
	26 x 1 x 42 ¹ / ₄	660 x 25 x 1072	KPLMS-4226-NN-__	745	
	32 x 1 x 42 ¹ / ₄	813 x 25 x 1072	KPLMS-4232-NN-__	777	
	38 x 1 x 42 ¹ / ₄	965 x 25 x 1072	KPLMS-4238-NN-__	802	
	50 x 1 x 42 ¹ / ₄	1270 x 25 x 1072	KPLMS-4250-NN-__	828	
	62 x 1 x 42 ¹ / ₄	1575 x 25 x 1072	KPLMS-4262-NN-__	853	
	22 x 1 x 48 ³ / ₈	559 x 25 x 1229	KPLMS-4822-NN-__	745	
	26 x 1 x 48 ³ / ₈	660 x 25 x 1229	KPLMS-4826-NN-__	777	
	32 x 1 x 48 ³ / ₈	813 x 25 x 1229	KPLMS-4832-NN-__	802	
	38 x 1 x 48 ³ / ₈	965 x 25 x 1229	KPLMS-4838-NN-__	834	
	50 x 1 x 48 ³ / ₈	1270 x 25 x 1229	KPLMS-4850-NN-__	865	
	62 x 1 x 48 ³ / ₈	1575 x 25 x 1229	KPLMS-4862-NN-__	896	
	22 x 1 x 54 ⁵ / ₈	559 x 25 x 1386	KPLMS-5422-NN-__	769	
	26 x 1 x 54 ⁵ / ₈	660 x 25 x 1386	KPLMS-5426-NN-__	802	
	32 x 1 x 54 ⁵ / ₈	813 x 25 x 1386	KPLMS-5432-NN-__	834	
	38 x 1 x 54 ⁵ / ₈	965 x 25 x 1386	KPLMS-5438-NN-__	870	
	50 x 1 x 54 ⁵ / ₈	1270 x 25 x 1386	KPLMS-5450-NN-__	904	
	62 x 1 x 54 ⁵ / ₈	1575 x 25 x 1386	KPLMS-5462-NN-__	936	
	At the end of the product code add, in this order: trim color, laminate finish.				

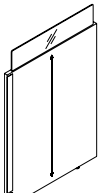
	W x D x H (in)	W x D x H (mm)	Code	Price (\$)
Laminate gallery panels with 6¹/₈" H glass, intersection, single				
<i>Is installed between two monolithic or segmented panels and serves as a return panel. Panel includes tempered glass screen and corner braces to fasten to the front of a surface. Note: Two end-of-run trims of variable height KVETS-__ are required if the monolithic or segmented panels are taller than the intersection panel; refer to page 28.</i>				
	29 ⁷ / ₈ " (758 mm) H panel with 6 ¹ / ₈ " (157 mm) H glass.			
	22 x 1 x 36	559 x 25 x 915	KPLMSG-3022-06-__	955
	26 x 1 x 36	660 x 25 x 915	KPLMSG-3026-06-__	972
	32 x 1 x 36	813 x 25 x 915	KPLMSG-3032-06-__	992
	38 x 1 x 36	965 x 25 x 915	KPLMSG-3038-06-__	1,023
	50 x 1 x 36	1270 x 25 x 915	KPLMSG-3050-06-__	1,074
	62 x 1 x 36	1575 x 25 x 915	KPLMSG-3062-06-__	1,119
	42 ¹ / ₄ " (1072 mm) H panel with 6 ¹ / ₈ " (157 mm) H glass.			
	22 x 1 x 48 ³ / ₈	559 x 25 x 1229	KPLMSG-4222-06-__	998
	26 x 1 x 48 ³ / ₈	660 x 25 x 1229	KPLMSG-4226-06-__	1,023
	32 x 1 x 48 ³ / ₈	813 x 25 x 1229	KPLMSG-4232-06-__	1,057
	38 x 1 x 48 ³ / ₈	965 x 25 x 1229	KPLMSG-4238-06-__	1,093
	50 x 1 x 48 ³ / ₈	1270 x 25 x 1229	KPLMSG-4250-06-__	1,151
	62 x 1 x 48 ³ / ₈	1575 x 25 x 1229	KPLMSG-4262-06-__	1,201
	48 ³ / ₈ " (1229 mm) H panel with 6 ¹ / ₈ " (157 mm) H glass.			
	22 x 1 x 54 ⁵ / ₈	559 x 25 x 1386	KPLMSG-4822-06-__	1,023
26 x 1 x 54 ⁵ / ₈	660 x 25 x 1386	KPLMSG-4826-06-__	1,057	
32 x 1 x 54 ⁵ / ₈	813 x 25 x 1386	KPLMSG-4832-06-__	1,088	
38 x 1 x 54 ⁵ / ₈	965 x 25 x 1386	KPLMSG-4838-06-__	1,133	
50 x 1 x 54 ⁵ / ₈	1270 x 25 x 1386	KPLMSG-4850-06-__	1,190	
62 x 1 x 54 ⁵ / ₈	1575 x 25 x 1386	KPLMSG-4862-06-__	1,241	
At the end of the product code add, in this order: trim color, laminate finish, clear (CG) or frosted (TG) finish for tempered glass (TG, surcharge of \$63).				

Contrary to the pictogram above, panels over 50" (1270 mm) W have a horizontal wood grain rather than a vertical one.

W x D x H (in)	W x D x H (mm)	Code	Price (\$)
Laminate gallery panels with 12 3/8" H glass, intersection, single			
<i>Is installed between two monolithic or segmented panels and serves as a return panel. Panel includes tempered glass screen and corner braces to fasten to the front of a surface. Note: Two end-of-run trims of variable height KVETS-__ are required if the monolithic or segmented panels are taller than the intersection panel; refer to page 28.</i>			
<i>29 7/8" (758 mm) H panel with 12 3/8" (314 mm) H glass.</i>			
22 x 1 x 42 1/4	559 x 25 x 1072	KPLMSG-3022-12-__	972
26 x 1 x 42 1/4	660 x 25 x 1072	KPLMSG-3026-12-__	998
32 x 1 x 42 1/4	813 x 25 x 1072	KPLMSG-3032-12-__	1,037
38 x 1 x 42 1/4	965 x 25 x 1072	KPLMSG-3038-12-__	1,074
50 x 1 x 42 1/4	1270 x 25 x 1072	KPLMSG-3050-12-__	1,139
62 x 1 x 42 1/4	1575 x 25 x 1072	KPLMSG-3062-12-__	1,195
<i>42 1/4" (1072 mm) H panel with 12 3/8" (314 mm) H glass.</i>			
22 x 1 x 54 3/8	559 x 25 x 1386	KPLMSG-4222-12-__	1,023
26 x 1 x 54 3/8	660 x 25 x 1386	KPLMSG-4226-12-__	1,049
32 x 1 x 54 3/8	813 x 25 x 1386	KPLMSG-4232-12-__	1,100
38 x 1 x 54 3/8	965 x 25 x 1386	KPLMSG-4238-12-__	1,144
50 x 1 x 54 3/8	1270 x 25 x 1386	KPLMSG-4250-12-__	1,215
62 x 1 x 54 3/8	1575 x 25 x 1386	KPLMSG-4262-12-__	1,278
At the end of the product code add, in this order: trim color, laminate finish, clear (CG) or frosted (TG) finish for tempered glass (TG, surcharge of \$108).			

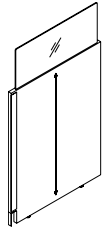

Contrary to the pictogram above, panels over 50" (1270 mm) W have a horizontal wood grain rather than a vertical one.

W x D x H (in)	W x D x H (mm)	Code	Price (\$)
Laminate gallery panels, intersection, shared			
<i>Is installed between two monolithic or segmented panels and serves as a return panel. Panel includes corner braces to fasten to the front of a surface. Note: Two end-of-run trims of variable height KVETS-__ are required if the monolithic or segmented panels are taller than the intersection panel; refer to page 28.</i>			
<i>42 x 1 x 29 7/8" (1067 x 25 x 758 mm) H panel with 12 3/8" (314 mm) H glass.</i>			
42 x 1 x 29 7/8	1067 x 25 x 758	KPLMD-3042-NN-__	737
50 x 1 x 29 7/8	1270 x 25 x 758	KPLMD-3050-NN-__	808
62 x 1 x 29 7/8	1575 x 25 x 758	KPLMD-3062-NN-__	870
74 x 1 x 29 7/8	1879 x 25 x 758	KPLMD-3074-NN-__	941
98 x 1 x 29 7/8	2489 x 25 x 758	KPLMD-3098-NN-__	1,011
<i>42 x 1 x 42 1/4" (1067 x 25 x 1072 mm) H panel with 12 3/8" (314 mm) H glass.</i>			
42 x 1 x 42 1/4	1067 x 25 x 1072	KPLMD-4242-NN-__	808
50 x 1 x 42 1/4	1270 x 25 x 1072	KPLMD-4250-NN-__	885
62 x 1 x 42 1/4	1575 x 25 x 1072	KPLMD-4262-NN-__	967
74 x 1 x 42 1/4	1879 x 25 x 1072	KPLMD-4274-NN-__	1,043
98 x 1 x 42 1/4	2489 x 25 x 1072	KPLMD-4298-NN-__	1,119
<i>42 x 1 x 48 3/8" (1067 x 25 x 1229 mm) H panel with 12 3/8" (314 mm) H glass.</i>			
42 x 1 x 48 3/8	1067 x 25 x 1229	KPLMD-4842-NN-__	839
50 x 1 x 48 3/8	1270 x 25 x 1229	KPLMD-4850-NN-__	921
62 x 1 x 48 3/8	1575 x 25 x 1229	KPLMD-4862-NN-__	1,011
74 x 1 x 48 3/8	1879 x 25 x 1229	KPLMD-4874-NN-__	1,093
98 x 1 x 48 3/8	2489 x 25 x 1229	KPLMD-4898-NN-__	1,177
<i>42 x 1 x 54 3/8" (1067 x 25 x 1386 mm) H panel with 12 3/8" (314 mm) H glass.</i>			
42 x 1 x 54 3/8	1067 x 25 x 1386	KPLMD-5442-NN-__	870
50 x 1 x 54 3/8	1270 x 25 x 1386	KPLMD-5450-NN-__	961
62 x 1 x 54 3/8	1575 x 25 x 1386	KPLMD-5462-NN-__	1,057
74 x 1 x 54 3/8	1879 x 25 x 1386	KPLMD-5474-NN-__	1,144
98 x 1 x 54 3/8	2489 x 25 x 1386	KPLMD-5498-NN-__	1,234
At the end of the product code add, in this order: trim color, laminate finish.			

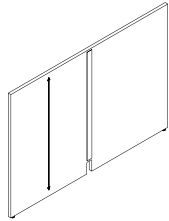

Contrary to the pictogram above, panels over 50" (1270 mm) W have a horizontal wood grain rather than a vertical one.

W x D x H (in)	W x D x H (mm)	Code	Price (\$)
Laminate gallery panels with 6 1/8" H glass, intersection, shared			
<i>Is installed between two monolithic or segmented panels and serves as a return panel. Panel includes tempered glass screens and corner braces to fasten to the front of a surface. Note: Two end-of-run trims of variable height KVETS-__ are required if the monolithic or segmented panels are taller than the intersection panel; refer to page 28.</i>			
<i>29 7/8" (758 mm) H panel with 6 1/8" (157 mm) H glass.</i>			
42 x 1 x 36	1067 x 25 x 915	KPLMDG-3042-06-__	1,125
50 x 1 x 36	1270 x 25 x 915	KPLMDG-3050-06-__	1,195
62 x 1 x 36	1575 x 25 x 915	KPLMDG-3062-06-__	1,266
74 x 1 x 36	1879 x 25 x 915	KPLMDG-3074-06-__	1,361
98 x 1 x 36	2489 x 25 x 915	KPLMDG-3098-06-__	1,482
<i>42 1/4" (1072 mm) H panel with 6 1/8" (157 mm) H glass.</i>			
42 x 1 x 48 3/8	1067 x 25 x 1229	KPLMDG-4242-06-__	1,195
50 x 1 x 48 3/8	1270 x 25 x 1229	KPLMDG-4250-06-__	1,272
62 x 1 x 48 3/8	1575 x 25 x 1229	KPLMDG-4262-06-__	1,354
74 x 1 x 48 3/8	1879 x 25 x 1229	KPLMDG-4274-06-__	1,463
98 x 1 x 48 3/8	2489 x 25 x 1229	KPLMDG-4298-06-__	1,596

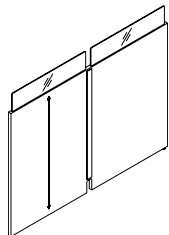

W x D x H (in)	W x D x H (mm)	Code	Price (\$)
Laminate gallery panels with 6 1/8" H glass, intersection, shared (cont'd)			
<i>48 3/8" (1229 mm) H panel with 6 1/8" (157 mm) H glass.</i>			
42 x 1 x 54 3/8	1067 x 25 x 1386	KPLMDG-4842-06-__	1,227
50 x 1 x 54 3/8	1270 x 25 x 1386	KPLMDG-4850-06-__	1,310
62 x 1 x 54 3/8	1575 x 25 x 1386	KPLMDG-4862-06-__	1,405
74 x 1 x 54 3/8	1879 x 25 x 1386	KPLMDG-4874-06-__	1,514
98 x 1 x 54 3/8	2489 x 25 x 1386	KPLMDG-4898-06-__	1,654
Contrary to the preceding pictogram, panels over 50" (1270 mm) W have a horizontal wood grain rather than a vertical one.			

W x D x H (in)	W x D x H (mm)	Code	Price (\$)
Laminate gallery panels with 12 3/8" H glass, intersection, shared			
<i>Is installed between two monolithic or segmented panels and serves as a return panel. Panel includes tempered glass screens and corner braces to fasten to the front of a surface. Note: Two end-of-run trims of variable height KVETS-__ are required if the monolithic or segmented panels are taller than the intersection panel; refer to page 28.</i>			
<i>29 7/8" (758 mm) H panel with 12 3/8" (314 mm) H glass.</i>			
42 x 1 x 42 1/4	1067 x 25 x 1072	KPLMDG-3042-12-__	1,177
50 x 1 x 42 1/4	1270 x 25 x 1072	KPLMDG-3050-12-__	1,246
62 x 1 x 42 1/4	1575 x 25 x 1072	KPLMDG-3062-12-__	1,354
74 x 1 x 42 1/4	1879 x 25 x 1072	KPLMDG-3074-12-__	1,456
98 x 1 x 42 1/4	2489 x 25 x 1072	KPLMDG-3098-12-__	1,608
<i>42 1/4" (1072 mm) H panel with 12 3/8" (314 mm) H glass.</i>			
42 x 1 x 54 3/8	1067 x 25 x 1386	KPLMDG-4242-12-__	1,241
50 x 1 x 54 3/8	1270 x 25 x 1386	KPLMDG-4250-12-__	1,323
62 x 1 x 54 3/8	1575 x 25 x 1386	KPLMDG-4262-12-__	1,444
74 x 1 x 54 3/8	1879 x 25 x 1386	KPLMDG-4274-12-__	1,558
98 x 1 x 54 3/8	2489 x 25 x 1386	KPLMDG-4298-12-__	1,724
At the end of the product code add, in this order: trim color, laminate finish, clear (CG) or frosted (TG) finish for tempered glass (TG, surcharge of \$108).			

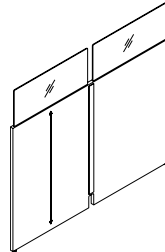

Contrary to the pictogram above, panels over 50" (1270 mm) W have a horizontal wood grain rather than a vertical one.

SCREENS AND STACKABLE PANELS

W x D x H (in)	W x D x H (mm)	Code	Price (\$)
Privacy screens for panels			
<i>Privacy screen includes tempered glass screen and top trim. Is installed on top of a monolithic or segmented panel or of a stackable panel of equal width.</i>			
<i>6 1/8" (157 mm) H.</i>			
23 1/8 x 2 x 6 1/8	593 x 51 x 157	KPFG-0624-__	312
29 1/8 x 2 x 6 1/8	745 x 51 x 157	KPFG-0630-__	331
35 1/8 x 2 x 6 1/8	897 x 51 x 157	KPFG-0636-__	362
41 1/8 x 2 x 6 1/8	1050 x 51 x 157	KPFG-0642-__	395
47 1/8 x 2 x 6 1/8	1202 x 51 x 157	KPFG-0648-__	426
59 1/8 x 2 x 6 1/8	1507 x 51 x 157	KPFG-0660-__	484
<i>12 3/8" (314 mm) H.</i>			
23 1/8 x 2 x 12 3/8	593 x 51 x 314	KPFG-1224-__	344
29 1/8 x 2 x 12 3/8	745 x 51 x 314	KPFG-1230-__	382
35 1/8 x 2 x 12 3/8	897 x 51 x 314	KPFG-1236-__	421
41 1/8 x 2 x 12 3/8	1050 x 51 x 314	KPFG-1242-__	464
47 1/8 x 2 x 12 3/8	1202 x 51 x 314	KPFG-1248-__	503
59 1/8 x 2 x 12 3/8	1507 x 51 x 314	KPFG-1260-__	573
At the end of the product code add, in this order: trim color, clear (CG) or frosted (TG) finish for tempered glass (TG, surcharge of \$63 for 6 1/8" H screen and surcharge of \$108 for 12 3/8" H screen).			

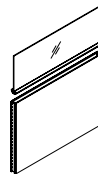

W x D x H (in)	W x D x H (mm)	Code	Price (\$)
Glass stackable panels			
<i>Stackable panel includes tempered glass segment, in-line junction connectors and side rails. Is installed on top of a monolithic or segmented panel or of a stackable panel of equal width.</i>			
<i>12 3/8" (314 mm) H.</i>			
24 x 2 x 12 3/8	610 x 51 x 314	KPSG-1224-__	675
30 x 2 x 12 3/8	762 x 51 x 314	KPSG-1230-__	719
36 x 2 x 12 3/8	914 x 51 x 314	KPSG-1236-__	777
42 x 2 x 12 3/8	1067 x 51 x 314	KPSG-1242-__	828
48 x 2 x 12 3/8	1219 x 51 x 314	KPSG-1248-__	890
60 x 2 x 12 3/8	1524 x 51 x 314	KPSG-1260-__	986
<i>24 3/4" (628 mm) H.</i>			
24 x 2 x 24 3/4	610 x 51 x 628	KPSG-2424-__	719
30 x 2 x 24 3/4	762 x 51 x 628	KPSG-2430-__	763



	W x D x H (in)	W x D x H (mm)	Code	Price (\$)
Glass stackable panels (cont'd)	36 x 2 x 24 ³ / ₄	914 x 51 x 628	KPSG-2436-___	820
	42 x 2 x 24 ³ / ₄	1067 x 51 x 628	KPSG-2442-___	885
	48 x 2 x 24 ³ / ₄	1219 x 51 x 628	KPSG-2448-___	947
	60 x 2 x 24 ³ / ₄	1524 x 51 x 628	KPSG-2460-___	1,057

At the end of the product code add, in this order: trim color, clear (CG) or frosted (TG) finish for tempered glass (TG, surcharge of \$63 for 12³/₈" H panel and surcharge of \$153 for 24³/₄" H panel).

Fabric acoustical stackable panels

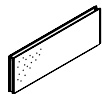

A combination of upholsteries may be applied to each side of a stackable panel. If they are of different grades, the cost of the upholstery will be based on the price of the higher grade.

Stackable panel includes in-line junction connectors and side rails. Is installed on top of a monolithic or segmented panel or of a stackable panel of equal width.

		Gr1	Gr2	Gr3
<i>12³/₈" (314 mm) H.</i>				
24 x 2 x 12 ³ / ₈	610 x 51 x 314	KPSA-1224-___	464	515 566
30 x 2 x 12 ³ / ₈	762 x 51 x 314	KPSA-1230-___	509	560 610
36 x 2 x 12 ³ / ₈	914 x 51 x 314	KPSA-1236-___	560	610 661
42 x 2 x 12 ³ / ₈	1067 x 51 x 314	KPSA-1242-___	617	668 719
48 x 2 x 12 ³ / ₈	1219 x 51 x 314	KPSA-1248-___	675	726 777
60 x 2 x 12 ³ / ₈	1524 x 51 x 314	KPSA-1260-___	777	828 878
<i>24³/₄" (628 mm) H.</i>				
24 x 2 x 24 ³ / ₄	610 x 51 x 628	KPSA-2424-___	503	553 604
30 x 2 x 24 ³ / ₄	762 x 51 x 628	KPSA-2430-___	553	604 655
36 x 2 x 24 ³ / ₄	914 x 51 x 628	KPSA-2436-___	610	661 712
42 x 2 x 24 ³ / ₄	1067 x 51 x 628	KPSA-2442-___	668	719 769
48 x 2 x 24 ³ / ₄	1219 x 51 x 628	KPSA-2448-___	737	788 839
60 x 2 x 24 ³ / ₄	1524 x 51 x 628	KPSA-2460-___	839	890 941

At the end of the product code add, in this order: trim color, upholstery for sides A/B.

Laminate stackable panels

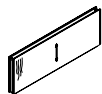

A combination of HPL finishes may be applied to each side of a module.

Stackable panel includes in-line junction connectors and side rails. Is installed on top of a monolithic or segmented panel or of a stackable panel of equal width.

				\$
<i>12³/₈" (314 mm) H.</i>				
24 x 2 x 12 ³ / ₈	610 x 51 x 314	KPSL-1224-___		853
30 x 2 x 12 ³ / ₈	762 x 51 x 314	KPSL-1230-___		874
36 x 2 x 12 ³ / ₈	914 x 51 x 314	KPSL-1236-___		900
42 x 2 x 12 ³ / ₈	1067 x 51 x 314	KPSL-1242-___		967
48 x 2 x 12 ³ / ₈	1219 x 51 x 314	KPSL-1248-___		986
<i>24³/₄" (628 mm) H.</i>				
24 x 2 x 24 ³ / ₄	610 x 51 x 628	KPSL-2424-___		1,026
30 x 2 x 24 ³ / ₄	762 x 51 x 628	KPSL-2430-___		1,060
36 x 2 x 24 ³ / ₄	914 x 51 x 628	KPSL-2436-___		1,080
42 x 2 x 24 ³ / ₄	1067 x 51 x 628	KPSL-2442-___		1,225
48 x 2 x 24 ³ / ₄	1219 x 51 x 628	KPSL-2448-___		1,260

At the end of the product code add, in this order: trim color, HPL finishes for sides A/B.

Laminate/fabric combined stackable panels

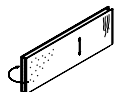

Stackable panel includes in-line junction connectors and side rails. Is installed on top of a monolithic or segmented panel or of a stackable panel of equal width.

		Gr1	Gr2	Gr3
<i>12³/₈" (314 mm) H.</i>				
24 x 2 x 12 ³ / ₈	610 x 51 x 314	KPSC-1224-___	814	839 865
30 x 2 x 12 ³ / ₈	762 x 51 x 314	KPSC-1230-___	834	859 885
36 x 2 x 12 ³ / ₈	914 x 51 x 314	KPSC-1236-___	865	890 916
42 x 2 x 12 ³ / ₈	1067 x 51 x 314	KPSC-1242-___	910	936 961
48 x 2 x 12 ³ / ₈	1219 x 51 x 314	KPSC-1248-___	929	955 980
<i>24³/₄" (628 mm) H.</i>				
24 x 2 x 24 ³ / ₄	610 x 51 x 628	KPSC-2424-___	967	992 1,018
30 x 2 x 24 ³ / ₄	762 x 51 x 628	KPSC-2430-___	992	1,018 1,043
36 x 2 x 24 ³ / ₄	914 x 51 x 628	KPSC-2436-___	1,018	1,043 1,069
42 x 2 x 24 ³ / ₄	1067 x 51 x 628	KPSC-2442-___	1,108	1,133 1,159
48 x 2 x 24 ³ / ₄	1219 x 51 x 628	KPSC-2448-___	1,125	1,151 1,177

At the end of the product code add, in this order: trim color, HPL finish for side A, upholstery for side B.

PANEL COMPONENTS

Vertical trim, top cap and 90-degree junction connector included.

L-junction kits, full height	W x D x H (in)	W x D x H (mm)	Code	Price (\$)
	2 x 2 x 29 ⁷ / ₈	51 x 51 x 758	KVPL-30-___	224
	2 x 2 x 42 ¹ / ₄	51 x 51 x 1072	KVPL-42-___	249
	2 x 2 x 48 ³ / ₈	51 x 51 x 1229	KVPL-48-___	261
	2 x 2 x 54 ³ / ₈	51 x 51 x 1386	KVPL-54-___	272
	2 x 2 x 66 ⁷ / ₈	51 x 51 x 1700	KVPL-66-___	285

Specify trim color.

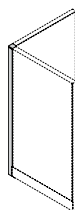

Vertical trim, top cap and 90-degree junction connectors included.

T-junction kits, full height	W x D x H (in)	W x D x H (mm)	Code	Price (\$)
	2 x 2 x 29 ⁷ / ₈	51 x 51 x 758	KVPT-30-___	139
	2 x 2 x 42 ¹ / ₄	51 x 51 x 1072	KVPT-42-___	152
	2 x 2 x 48 ³ / ₈	51 x 51 x 1229	KVPT-48-___	158
	2 x 2 x 54 ³ / ₈	51 x 51 x 1386	KVPT-54-___	163
	2 x 2 x 66 ⁷ / ₈	51 x 51 x 1700	KVPT-66-___	175

Specify trim color.

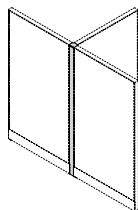

Top cap and 90-degree junction connectors included.

X-junction kits, full height	W x D x H (in)	W x D x H (mm)	Code	Price (\$)
	2 x 2 x 29 ⁷ / ₈	51 x 51 x 758	KVPX-30-___	139
	2 x 2 x 42 ¹ / ₄	51 x 51 x 1072	KVPX-42-___	152
	2 x 2 x 48 ³ / ₈	51 x 51 x 1229	KVPX-48-___	158
	2 x 2 x 54 ³ / ₈	51 x 51 x 1386	KVPX-54-___	163
	2 x 2 x 66 ⁷ / ₈	51 x 51 x 1700	KVPX-66-___	175

Specify trim color.

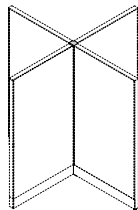

End-of-run trim and top cap included. Required at end of each run of panels.

End-of-run trims, full height	W x D x H (in)	W x D x H (mm)	Code	Price (\$)
	2 x 1/2 x 29 ⁷ / ₈	51 x 13 x 758	KVET-30-___	198
	2 x 1/2 x 42 ¹ / ₄	51 x 13 x 1072	KVET-42-___	210
	2 x 1/2 x 48 ³ / ₈	51 x 13 x 1229	KVET-48-___	216
	2 x 1/2 x 54 ³ / ₈	51 x 13 x 1386	KVET-54-___	223
	2 x 1/2 x 66 ⁷ / ₈	51 x 13 x 1700	KVET-66-___	235

Specify trim color.

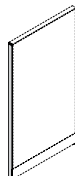

Includes vertical trim, end-of-run trim, top caps and 90-degree junction connector. Dimension in the product code indicates height of tallest panel.

L-junction kits, variable height	W x D x H (in)	W x D x H (mm)	Code	Price (\$)
	2 x 2 x 42 ¹ / ₄	51 x 51 x 1072	KVPLA-42-___	249
	2 x 2 x 48 ³ / ₈	51 x 51 x 1229	KVPLA-48-___	261
	2 x 2 x 54 ³ / ₈	51 x 51 x 1386	KVPLA-54-___	272
	2 x 2 x 66 ⁷ / ₈	51 x 51 x 1700	KVPLA-66-___	285

Specify height of lowest panel. Specify trim color.

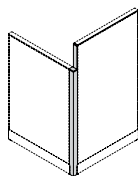

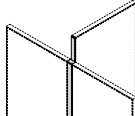
	W x D x H (in)	W x D x H (mm)	Code	Price (\$)
T-junction kits, type A, variable height	<i>Includes vertical trim, end-of-run trim, top caps and 90-degree junction connectors. Dimension in the product code indicates height of tallest panel.</i>			
	2 x 2 x 42 ¹ / ₄	51 x 51 x 1072	KVPTA-42-_-_-	158
	2 x 2 x 48 ³ / ₈	51 x 51 x 1229	KVPTA-48-_-_-	170
	2 x 2 x 54 ⁷ / ₈	51 x 51 x 1386	KVPTA-54-_-_-	175
	2 x 2 x 66 ⁷ / ₈	51 x 51 x 1700	KVPTA-66-_-_-	182
	Specify height of lowest panels. Specify trim color.			

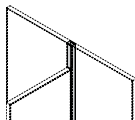
	W x D x H (in)	W x D x H (mm)	Code	Price (\$)
T-junction kits, type B, variable height	<i>Includes vertical trim, top caps and 90-degree junction connectors. Dimension in the product code indicates height of tallest panels.</i>			
	2 x 2 x 42 ¹ / ₄	51 x 51 x 1072	KVPTB-42-_-_-	158
	2 x 2 x 48 ³ / ₈	51 x 51 x 1229	KVPTB-48-_-_-	170
	2 x 2 x 54 ⁷ / ₈	51 x 51 x 1386	KVPTB-54-_-_-	175
	2 x 2 x 66 ⁷ / ₈	51 x 51 x 1700	KVPTB-66-_-_-	182
	Specify height of lowest panel. Specify trim color.			

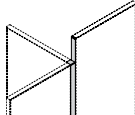
	W x D x H (in)	W x D x H (mm)	Code	Price (\$)
T-junction kits, type C, variable height	<i>Includes vertical trim, end-of-run trim, top caps and 90-degree junction connectors. Dimension in the product code indicates height of tallest panels.</i>			
	2 x 2 x 42 ¹ / ₄	51 x 51 x 1072	KVPTC-42-_-_-	158
	2 x 2 x 48 ³ / ₈	51 x 51 x 1229	KVPTC-48-_-_-	170
	2 x 2 x 54 ⁷ / ₈	51 x 51 x 1386	KVPTC-54-_-_-	175
	2 x 2 x 66 ⁷ / ₈	51 x 51 x 1700	KVPTC-66-_-_-	182
	Specify height of lowest panels. Specify trim color.			

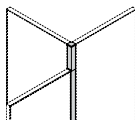
	W x D x H (in)	W x D x H (mm)	Code	Price (\$)
T-junction kits, type D, variable height	<i>Includes vertical trim, top caps and 90-degree junction connectors. Dimension in the product code indicates height of tallest panels.</i>			
	2 x 2 x 42 ¹ / ₄	51 x 51 x 1072	KVPTD-42-_-_-	158
	2 x 2 x 48 ³ / ₈	51 x 51 x 1229	KVPTD-48-_-_-	170
	2 x 2 x 54 ⁷ / ₈	51 x 51 x 1386	KVPTD-54-_-_-	175
	2 x 2 x 66 ⁷ / ₈	51 x 51 x 1700	KVPTD-66-_-_-	182
	Specify height of lowest panel. Specify trim color.			

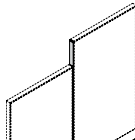
	W x D x H (in)	W x D x H (mm)	Code	Price (\$)
End-of-run trims, variable height	<i>Includes end-of-run trim and top caps. Required for an in-line change of height, a lower laminate gallery panel or with a stackable panel at a workstation end-of-run.</i>			
	2 x 1/2 x 6 ¹ / ₈	51 x 13 x 156	KVETS-6-_-_-	180
	2 x 1/2 x 12 ³ / ₈	51 x 13 x 314	KVETS-12-_-_-	191
	2 x 1/2 x 18 ¹ / ₂	51 x 13 x 472	KVETS-18-_-_-	198
	2 x 1/2 x 24 ³ / ₄	51 x 13 x 628	KVETS-24-_-_-	204
	Specify trim color.			

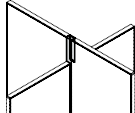
	W x D x H (in)	W x D x H (mm)	Code	Price (\$)
X-junction kits, type A, variable height	<i>Includes vertical trim, top caps and 90-degree junction connectors. Dimension in the product code indicates height of tallest panels.</i>			
	2 x 2 x 42 ¹ / ₄	51 x 51 x 1072	KVPXA-42-_-_-	158
	2 x 2 x 48 ³ / ₈	51 x 51 x 1229	KVPXA-48-_-_-	170
	2 x 2 x 54 ⁷ / ₈	51 x 51 x 1386	KVPXA-54-_-_-	175
	2 x 2 x 66 ⁷ / ₈	51 x 51 x 1700	KVPXA-66-_-_-	182
	Specify height of lowest panels. Specify trim color.			

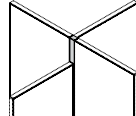
	W x D x H (in)	W x D x H (mm)	Code	Price (\$)
X-junction kits, type B, variable height	<i>Includes vertical trim, top caps and 90-degree junction connectors. Dimension in the product code indicates height of tallest panels.</i>			
	2 x 2 x 42 ¹ / ₄	51 x 51 x 1072	KVPXB-42-_-_-	158
	2 x 2 x 48 ³ / ₈	51 x 51 x 1229	KVPXB-48-_-_-	170
	2 x 2 x 54 ⁷ / ₈	51 x 51 x 1386	KVPXB-54-_-_-	175
	2 x 2 x 66 ⁷ / ₈	51 x 51 x 1700	KVPXB-66-_-_-	182
	Specify height of lowest panel. Specify trim color.			

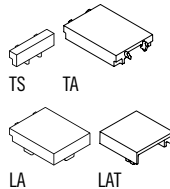
	W x D x H (in)	W x D x H (mm)	Code	Price (\$)
Top caps	<i>Required for certain applications that use center-mounted laminate storage units or transaction countertops; refer to page 7.</i>			
	2 x 3/8 x 1/2	51 x 10 x 14	KVCP-TS-_-_-	51
	2 x 2 1/2 x 1/2	51 x 64 x 14	KVCP-LA-_-_-	51
	2 x 3 x 1/2	51 x 76 x 14	KVCP-TA-_-_-	51
	2 x 3 x 1/2	51 x 76 x 14	KVCP-LAT-_-_-	51
	Specify trim color.			

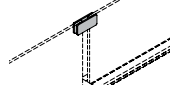
	W x D x H (in)	W x D x H (mm)	Code	Price (\$)
Alignment hardware for glass privacy screens	<i>For use with glass privacy screens (KPGF). To align the top of glass privacy screens in a straight line application (if required). Cannot join two glass privacy screens separated by a junction kit or a laminate intersection gallery panel. Pack of 4.</i>			
	3/8 x 3/4 x 60 ³ / ₄	17 x 19 x 1543	KPGF-ALIGN-S-_-_-	193
	Specify trim color.			

	W x D x H (in)	W x D x H (mm)	Code	Price (\$)
Wall starter	<i>For connecting a run of panels to a structural wall. Includes wall starter and in-line junction connectors. Anchors not included. Note: Wall mounting bracket is shorter than total panel height in order to allow access to raceway.</i>			
	2 x 1/2 x 23 ³ / ₈	51 x 13 x 600	KVWS-30-_-_-	121
	2 x 1/2 x 36	51 x 13 x 914	KVWS-42-_-_-	128
	2 x 1/2 x 42 ¹ / ₈	51 x 13 x 1071	KVWS-48-_-_-	133
	2 x 1/2 x 48 ³ / ₈	51 x 13 x 1228	KVWS-54-_-_-	140
	2 x 1/2 x 60 ³ / ₄	51 x 13 x 1543	KVWS-66-_-_-	140
	Specify trim color.			

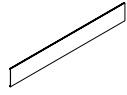
	W x D x H (in)	W x D x H (mm)	Code	Price (\$)
Raceway covers	<i>Covers with or without cut-outs for duplex receptacles and communication plates. Pack of 1. To be ordered separately: KVCP-6 covers for unused electrical receptacle cut-outs; refer to page 8.</i>			
	24 x 1/4 x 5	610 x 6 x 127	KVRC-24-_-_-	198
No cut-outs (N)	30 x 1/4 x 5	762 x 6 x 127	KVRC-30-_-_-	210
	36 x 1/4 x 5	914 x 6 x 127	KVRC-36-_-_-	223
	42 x 1/4 x 5	1067 x 6 x 127	KVRC-42-_-_-	235
	48 x 1/4 x 5	1219 x 6 x 127	KVRC-48-_-_-	249
	60 x 1/4 x 5	1524 x 6 x 127	KVRC-60-_-_-	261
	Specify type of cover (N, P, H). Specify trim color.			

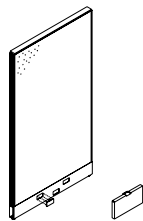
	W x D x H (in)	W x D x H (mm)	Code	Price (\$)
Covers for raceway cut-outs	<i>Required for unused duplex and communication receptacle cut-outs. Not compatible with Chicago (H) electrical cut-outs. Pack of 6.</i>			
	3 1/8 x 1/2 x 2 1/8	79 x 13 x 54	KVCP-6-_-_-	84
	Specify trim color.			

ELECTRICITY

IMPORTANT: The electrical components for a 3-circuit, 5-wire system differ from those for a 4-circuit, 8-wire system. These components are not interchangeable from one system to the other. Accordingly, special attention is required during specification. Take note of whether the product code includes the digit '3' or '4'.

ELECTRICAL COMPONENTS – 3-CIRCUIT SYSTEM

	W x D x H (in)	W x D x H (mm)	Code	Price (\$)
Hardwire base feed	<i>Enables connection of electric system to the floor or wall. Connects to electric system at the location of the receptacle. Note: The housing exceeds the raceway by 1½" (38 mm). Check the clearance required before installing storage units.</i>			
	72	1829	KEB3-S-6	292

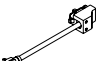
Plug-in base feed, 20-amp	<i>Enables connection of electric system to a 20-amp outlet. Connects to electric system at the location of the receptacle. Powers circuit No. 1 only. UL Recognized, cUL Approved. Note: The housing exceeds the raceway by 1½" (38 mm). Check the clearance required before installing storage units.</i>			
	24	610	KEB3-P-2	300

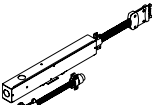
Concealed base feed	<i>Enables connection of electric system to the floor or wall. Meets the standards of the New York City Building Code. Inserts into a non-powered panel and connects in-line to the adjacent panel's electric panel. Mounting brackets included. Note: Requires piercing of raceway cover. A cover with a Type P cut-out may also be ordered separately.</i>			
	72	1829	KEB3-C-6	417

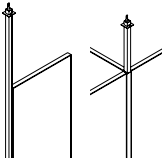
Powered feed poles	<i>Enables connection of electric system and the running of communication cables to a ceiling with a maximum height of 12' (3657 mm). Connects to the end of an electric system. Includes pole, top caps, ceiling cover plate, power feed and a Y connector.</i>			
	<i>To be installed at end of panel run.</i>			
	144	3657	KET3-12-___	1,354
	<i>To be installed on an L, T or X junction kit.</i>			
	114	2895	KET3-9-___	1,205

Specify trim color.
KET3-12 KET3-9

Duplex receptacles, 15-amp	<i>Common ground. Pack of 10.</i>			
	3½ x 1⅜ x 1½	88 x 35 x 45	KER3-C-__	362

Specify type of circuit (1, 2, 3). Specify Black (K) or White (W) color.

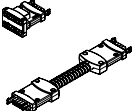
Power connectors for junctions	<i>Required only to power panels separated by a junction kit; refer to page 10. Note: Used as a complement to the electric connector supplied with each powered panel.</i>			
	<i>For L or Type S connection (includes a Y connector).</i>			
			KEJ3-LS	72
	<i>For T connection (includes a Y connector and a junction connector).</i>			
			KEJ3-T	141
	<i>For X connection (includes two Y connectors and two junction connectors).</i>			
			KEJ3-X	173
	<i>For Type G connection (includes a junction connector).</i>			
			KEJ3-G	110

ELECTRICAL COMPONENTS – 4-CIRCUIT SYSTEM

Pass-thru jumper cables for non-powered panel	<i>Required only to connect two panels separated by one or several non-powered panel(s). Connector length is adjustable in order to enable a connection through a junction kit. Note: Connector length is 18" (457 mm) greater than the total width of the panel(s) to be crossed.</i>			
--	---	--	--	--

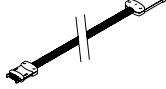
	24" (610 mm) W panel	KEJL3-24	151
	30" (762 mm) W panel	KEJL3-30	158
	36" (914 mm) W panel	KEJL3-36	165
	42" (1067 mm) W panel	KEJL3-42	173
	48" (1219 mm) W panel(s)	KEJL3-48	182
	60" (1524 mm) W panel(s)	KEJL3-60	198
	66" (1676 mm) W panels	KEJL3-66	223
	72" (1829 mm) W panels	KEJL3-72	243
	78" (1981 mm) W panels	KEJL3-78	264
	84" (2134 mm) W panels	KEJL3-84	285
	90" (2283 mm) W panels	KEJL3-90	305
	96" (2438 mm) W panels	KEJL3-96	326
	102" (2591 mm) W panels	KEJL3-102	346
	108" (2743 mm) W panels	KEJL3-108	367
	120" (3048 mm) W panels	KEJL3-120	387

Electrical retrofit kits	<i>Enables retrofit connection of a non-powered panel. Electric system, in-line junction connector and mounting brackets included.</i>			
---------------------------------	--	--	--	--

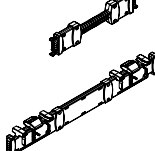
	24" (610 mm) W panel	KEP3-24	205
	30" (762 mm) W panel	KEP3-30	252
	36" (914 mm) W panel	KEP3-36	268
	42" (1067 mm) W panel	KEP3-42	283
	48" (1219 mm) W panel	KEP3-48	292
	60" (1524 mm) W panel	KEP3-60	386

ELECTRICAL COMPONENTS – 4-CIRCUIT SYSTEM

Hardwire base feed	<i>Enables connection of electric system to the floor or wall. Connects to electric system at the location of the receptacle. Note: The housing exceeds the raceway by 1½" (38 mm). Check the clearance required before installing storage units.</i>			
	72	1829	KEB4-S-6	362

Plug-in base feed, 20-amp	<i>Enables connection of electric system to a 20-amp outlet. Connects to electric system at the location of the receptacle. Powers circuit No. 1 only. UL Recognized, cUL Approved. Note: The housing exceeds the raceway by 1½" (38 mm). Check the clearance required before installing storage units.</i>			
	24	610	KEB4-P-2	300

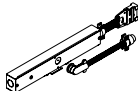
Concealed base feed	<i>Enables connection of electric system to the floor or wall. Meets the standards of the New York City Building Code. Inserts into a non-powered panel and connects in-line to the adjacent panel's electric panel. Mounting brackets included. Note: Requires piercing of raceway cover. A cover with a Type P cut-out may also be ordered separately.</i>			
	72	1829	KEB4-C-6	410

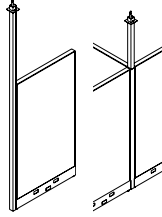
Powered feed poles	<i>Enables connection of electric system and the running of communication cables to a ceiling with a maximum height of 12" (3657 mm). Connects to the end of an electric system. Includes pole, top caps, ceiling cover plate and power feed.</i>			
	<i>To be installed at end of panel run.</i>			
	144	3657	KET4-12-___	1,464

	<i>To be installed on an L, T or X junction kit.</i>			
	114	2895	KET4-9-___	1,316

Specify trim color.
KET4-12 KET4-9

	W x D x H (in)	W x D x H (mm)	Code	Price (\$)
Duplex receptacles, 15-amp	<i>Common ground. Type D4 receptacle identified by an orange triangle indicates that the circuit is dedicated and isolated. Pack of 10.</i>			
	<i>Common ground.</i>			
	3 1/2 x 1 3/8 x 1 3/8	88 x 35 x 35	KER4-C -	410
	<i>Isolated and dedicated circuit.</i>			
	3 1/2 x 1 3/8 x 1 3/8	88 x 35 x 35	KER4-D4 -	410

	W x D x H (in)	W x D x H (mm)	Code	Price (\$)
Power connectors for junction	<i>Required only to power panels separated by a junction kit; refer to page 10. For L or Type S connection (includes a junction connector).</i>			
			KEJ4-LS	189
			<i>For T connection (includes two junction connectors).</i>	
			KEJ4-T	346
			<i>For X connection (includes three junction connectors).</i>	
		KEJ4-X	496	
	<i>For Type G connection (includes a junction connector).</i>			
		KEJ4-G	189	

	W x D x H (in)	W x D x H (mm)	Code	Price (\$)
Pass-thru jumper cables for non-powered panel	<i>Required only to connect two panels separated by one or several non-powered panel(s). Connector length is adjustable in order to enable a connection through a junction kit. Note: Pass-thru jumper cables connect to 20" (508 mm) electrical connector supplied with each powered panel.</i>			
		24" (610 mm) W panel	KEJL4-24	198
		30" (762 mm) W panel	KEJL4-30	205
		36" (914 mm) W panel	KEJL4-36	213
		42" (1067 mm) W panel	KEJL4-42	220
		48" (1219 mm) W panel(s)	KEJL4-48	244
		60" (1524 mm) W panel(s)	KEJL4-60	268
		66" (1676 mm) W panels	KEJL4-66	301
		72" (1829 mm) W panels	KEJL4-72	330
		78" (1981 mm) W panels	KEJL4-78	359
		84" (2134 mm) W panels	KEJL4-84	387
		90" (2283 mm) W panels	KEJL4-90	416
		96" (2438 mm) W panels	KEJL4-96	445
	102" (2591 mm) W panels	KEJL4-102	475	
	108" (2743 mm) W panels	KEJL4-108	504	
	120" (3048 mm) W panels	KEJL4-120	534	

	W x D x H (in)	W x D x H (mm)	Code	Price (\$)
Electrical retrofit kits	<i>Enables retrofit connection of a non-powered panel. Electric system, in-line junction connector and mounting brackets included.</i>			
		24" (610 mm) W panel	KEP4-24	300
		30" (762 mm) W panel	KEP4-30	362
		36" (914 mm) W panel	KEP4-36	402
		42" (1067 mm) W panel	KEP4-42	417
		48" (1219 mm) W panel	KEP4-48	434
	60" (1524 mm) W panel	KEP4-60	457	

ELECTRICAL ACCESSORIES

	W x D x H (in)	W x D x H (mm)	Code	Price (\$)	
Electrified receptacles for work surface	<i>Mounts to rear of work surface; no drilling necessary. Pale gray plastic face with anodized aluminum housing. 6' (1829 mm) white cable.</i>				
	<i>2 power outlets.</i>				
		4 x 3 x 3 3/8	102 x 78 x 85	KLGC-PS2P	445
	<i>1 power outlet / 2 USB charging ports.</i>				
	4 x 3 x 3 3/8	102 x 78 x 85	KLGC-PS1USB1P	624	
<i>2 power outlets / 2 USB charging ports.</i>					
	5 1/2 x 3 x 3 3/8	140 x 78 x 85	KLGC-PS1USB2P	649	

	W x D x H (in)	W x D x H (mm)	Code	Price (\$)
Junction box - Chicago	<i>Enables a non-powered panel to be adapted to the standards of the Chicago Electric Code. Junction boxes and mounting brackets included. Certain components must be supplied by electrician. To be used with Type H covers; refer to page 28. Pack of 2.</i>			
		4 3/4 x 1 1/2 x 2 1/2	121 x 39 x 65	KEHB-2

	W x D x H (in)	W x D x H (mm)	Code	Price (\$)
Grommet-mounted receptacle	<i>1 power outlet / 2 USB charging ports. Liquid-proof. Mounting screw included. Silver. 108" (2743 mm) black cable.</i>			
		3 3/4 x 2 1/4 x 3 3/8	95 x 57 x 79	KLGC-PCQ1USB1P

	W x D x H (in)	W x D x H (mm)	Code	Price (\$)
Lamp	<i>In aluminum and silver plastic. Base with 6" (152 mm) diameter with USB charging port. Dimmer enables control of luminosity from 100% to 5% continuously. 10-hour automatic shut-off. 3500K, 85 CRI, 41 W, 18 LED. ETL certified (UL/CSA equivalent). 36" (914 mm) black cable.</i>			
		7 3/4 x 7 3/4 x 17	197 x 13 x 432	KELB-14USB

	W x D x H (in)	W x D x H (mm)	Code	Price (\$)	
Electronic fluorescent tasklights	<i>Electronic tubes do not cause interference. T5 - 4100K electronic ballast. 19": 10W, 25": 14W, 37": 21W, 49": 28W. Pivots with a 160-degree range to direct lighting. ETL certified (equivalent to UL/CSA). 108" (2743 mm) cable. Black.</i>				
		18 7/8 x 3 3/8 x 1	480 x 85 x 26	KLGC-T5LE19	356
		24 5/8 x 3 3/8 x 1	626 x 85 x 26	KLGC-T5LE25	395
		36 1/2 x 3 3/8 x 1	927 x 85 x 26	KLGC-T5LE37	438
		48 1/4 x 3 3/8 x 1	1226 x 85 x 26	KLGC-T5LE49	489

	W x D x H (in)	W x D x H (mm)	Code	Price (\$)
Data faceplates for raceway	<i>Inserts into raceway communication cut-out. Accepts up to 4 interlocking QuickPort adapters and connectors for voice and data applications, sold separately. Also compatible with Keystone connectors. Pack of 2.</i>			
		3 1/8 x 1/2 x 2 5/8	80 x 11 x 42	KEFC-2 -
	<i>Specify black (K) or white (W) color.</i>			

	W x D x H (in)	W x D x H (mm)	Code	Price (\$)	
Poles for network cables	<i>Enables running of communication cables to a ceiling with a maximum height of 12' (3657 mm). Includes pole, top caps and ceiling cover plate.</i>				
	<i>To be installed at end of panel run.</i>				
		144	3657	KETC-12 -	839
	<i>To be installed on an L, T or X junction kit.</i>				
	114	2895	KETC-9 -	719	
	<i>Specify trim color.</i>				

	W x D x H (in)	W x D x H (mm)	Code	Price (\$)
Cable management fasteners	<i>Facilitates cable management by pinching cables beneath the surface. Grey. Pack of 5.</i>			
		5 1/2 x 1 1/2 x 1	140 x 40 x 25	KLGC-WMC05

	W x D x H (in)	W x D x H (mm)	Code	Price (\$)
Fabric vertical cable cover	<i>Enables vertical cable management. 2" (50 mm) diameter. With zipper. Black fabric.</i>			
		2 x 2 x 26	50 x 50 x 660	KEVW-26

	W x D x H (in)	W x D x H (mm)	Code	Price (\$)
Junction box - Chicago	<i>Enables a non-powered panel to be adapted to the standards of the Chicago Electric Code. Junction boxes and mounting brackets included. Certain components must be supplied by electrician. To be used with Type H covers; refer to page 28. Pack of 2.</i>			
		4 3/4 x 1 1/2 x 2 1/2	121 x 39 x 65	KEHB-2

	W x D x H (in)	W x D x H (mm)	Code	Price (\$)
Junction box - Chicago	<i>Enables a non-powered panel to be adapted to the standards of the Chicago Electric Code. Junction boxes and mounting brackets included. Certain components must be supplied by electrician. To be used with Type H covers; refer to page 28. Pack of 2.</i>			
		4 3/4 x 1 1/2 x 2 1/2	121 x 39 x 65	KEHB-2

WORK SURFACE AND SUPPORTS

SURFACES

EXAMPLE: KUCEA-204872-34L-1-G-SNO

CODIFICATION

Series	Type of product	Surface dimension	Option	Orientation	Finish	Grommet	Color	
							Laminate/HPL	
K	UR Rectangular surface		C Curved	L Left	1 Thermofused laminate 1" (25 mm)	N None		
	UC Corner surface		K Straight	R Right	2 High-pressure laminate 1" (25 mm)	G Rectangular grommet		
	UCE Extended corner surface		3 Depth 20" (508 mm)					
			4 Depth 24" (610 mm)					
			5 Depth 30" (762 mm)					

W x D x H (in)	W x D x H (mm)	Code	Laminate (\$)	HPL (\$)
----------------	----------------	------	---------------	----------

WORK SURFACES WITH CABLE DROP

Rectangular surfaces with cable drop clearance at back

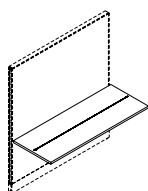

Surfaces with 1" (25 mm) clearance at back for grommet-free cable management. **To be ordered separately:** supports and bases; refer to page 34.

W x D x H (in)	W x D x H (mm)	Code	Laminate (\$)	HPL (\$)
<i>19" (483 mm) D surfaces, 1" (25 mm) clearance at back.</i>				
24 x 19 x 1	610 x 483 x 25	KUR-1924- -N- -	254	350
30 x 19 x 1	762 x 483 x 25	KUR-1930- -N- -	268	387
36 x 19 x 1	914 x 483 x 25	KUR-1936- -N- -	293	421
42 x 19 x 1	1067 x 483 x 25	KUR-1942- -N- -	324	458
48 x 19 x 1	1219 x 483 x 25	KUR-1948- -N- -	350	496
54 x 19 x 1	1372 x 483 x 25	KUR-1954- -N- -	370	535
60 x 19 x 1	1524 x 483 x 25	KUR-1960- -N- -	401	553
66 x 19 x 1	1676 x 483 x 25	KUR-1966- -N- -	445	592
72 x 19 x 1	1829 x 483 x 25	KUR-1972- -N- -	477	643
78 x 19 x 1	1981 x 483 x 25	KUR-1978- -N- -	496	686
84 x 19 x 1	2134 x 483 x 25	KUR-1984- -N- -	509	712
90 x 19 x 1	2286 x 483 x 25	KUR-1990- -N- -	541	751
96 x 19 x 1	2438 x 483 x 25	KUR-1996- -N- -	547	788
<i>23" (585 mm) D surfaces, 1" (25 mm) clearance at back.</i>				
24 x 23 x 1	610 x 585 x 25	KUR-2324- -N- -	312	433
30 x 23 x 1	762 x 585 x 25	KUR-2330- -N- -	336	471
36 x 23 x 1	914 x 585 x 25	KUR-2336- -N- -	362	503
42 x 23 x 1	1067 x 585 x 25	KUR-2342- -N- -	387	547
48 x 23 x 1	1219 x 585 x 25	KUR-2348- -N- -	421	592
54 x 23 x 1	1372 x 585 x 25	KUR-2354- -N- -	438	636
60 x 23 x 1	1524 x 585 x 25	KUR-2360- -N- -	471	661
66 x 23 x 1	1676 x 585 x 25	KUR-2366- -N- -	509	712
72 x 23 x 1	1829 x 585 x 25	KUR-2372- -N- -	553	769
78 x 23 x 1	1981 x 585 x 25	KUR-2378- -N- -	566	745
84 x 23 x 1	2134 x 585 x 25	KUR-2384- -N- -	586	783
90 x 23 x 1	2286 x 585 x 25	KUR-2390- -N- -	617	820
96 x 23 x 1	2438 x 585 x 25	KUR-2396- -N- -	675	921
<i>29" (737 mm) D surfaces, 1" (25 mm) clearance at back.</i>				
24 x 29 x 1	610 x 737 x 25	KUR-2924- -N- -	336	471
30 x 29 x 1	762 x 737 x 25	KUR-2930- -N- -	362	503
36 x 29 x 1	914 x 737 x 25	KUR-2936- -N- -	387	547
42 x 29 x 1	1067 x 737 x 25	KUR-2942- -N- -	421	592
48 x 29 x 1	1219 x 737 x 25	KUR-2948- -N- -	471	643
54 x 29 x 1	1372 x 737 x 25	KUR-2954- -N- -	489	661
60 x 29 x 1	1524 x 737 x 25	KUR-2960- -N- -	509	712
66 x 29 x 1	1676 x 737 x 25	KUR-2966- -N- -	553	769
72 x 29 x 1	1829 x 737 x 25	KUR-2972- -N- -	592	834
78 x 29 x 1	1981 x 737 x 25	KUR-2978- -N- -	617	865
84 x 29 x 1	2134 x 737 x 25	KUR-2984- -N- -	643	904
90 x 29 x 1	2286 x 737 x 25	KUR-2990- -N- -	661	941
96 x 29 x 1	2438 x 737 x 25	KUR-2996- -N- -	706	986

Specify the surface type (1, 2). Specify color.

Rectangular surfaces with cable drop clearance at back and on one side.

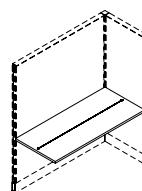

W x D x H (in)	W x D x H (mm)	Code	Laminate (\$)	HPL (\$)
----------------	----------------	------	---------------	----------

Surfaces with 1" (25 mm) clearance at back and an additional 1" (25 mm) clearance for grommet-free cable management. **To be ordered separately:** supports and bases; refer to page 34.

W x D x H (in)	W x D x H (mm)	Code	Laminate (\$)	HPL (\$)
<i>19" (483 mm) D surfaces, 1" (25 mm) clearance at back and on one side.</i>				
23 x 19 x 1	585 x 483 x 25	KUR-1923- -N- -	254	350
29 x 19 x 1	737 x 483 x 25	KUR-1929- -N- -	268	387
35 x 19 x 1	889 x 483 x 25	KUR-1935- -N- -	293	421
41 x 19 x 1	1041 x 483 x 25	KUR-1941- -N- -	324	458
47 x 19 x 1	1194 x 483 x 25	KUR-1947- -N- -	350	496
53 x 19 x 1	1346 x 483 x 25	KUR-1953- -N- -	370	535
59 x 19 x 1	1499 x 483 x 25	KUR-1959- -N- -	401	553
65 x 19 x 1	1651 x 483 x 25	KUR-1965- -N- -	445	592
71 x 19 x 1	1803 x 483 x 25	KUR-1971- -N- -	477	643
77 x 19 x 1	1956 x 483 x 25	KUR-1977- -N- -	496	686
83 x 19 x 1	2108 x 483 x 25	KUR-1983- -N- -	509	712
89 x 19 x 1	2261 x 483 x 25	KUR-1989- -N- -	541	751
95 x 19 x 1	2413 x 483 x 25	KUR-1995- -N- -	547	788
<i>23" (585 mm) D surfaces, 1" (25 mm) clearance at back and on one side.</i>				
23 x 23 x 1	585 x 585 x 25	KUR-2323- -N- -	312	433
29 x 23 x 1	737 x 585 x 25	KUR-2329- -N- -	336	471
35 x 23 x 1	889 x 585 x 25	KUR-2335- -N- -	362	503
41 x 23 x 1	1041 x 585 x 25	KUR-2341- -N- -	387	547
47 x 23 x 1	1194 x 585 x 25	KUR-2347- -N- -	421	592
53 x 23 x 1	1346 x 585 x 25	KUR-2353- -N- -	438	636
59 x 23 x 1	1499 x 585 x 25	KUR-2359- -N- -	471	661
65 x 23 x 1	1651 x 585 x 25	KUR-2365- -N- -	509	712
71 x 23 x 1	1803 x 585 x 25	KUR-2371- -N- -	553	769
77 x 23 x 1	1956 x 585 x 25	KUR-2377- -N- -	566	745
83 x 23 x 1	2108 x 585 x 25	KUR-2383- -N- -	586	783
89 x 23 x 1	2261 x 585 x 25	KUR-2389- -N- -	617	820
95 x 23 x 1	2413 x 585 x 25	KUR-2395- -N- -	675	921
<i>29" (737 mm) D surfaces, 1" (25 mm) clearance at back and on one side.</i>				
23 x 29 x 1	585 x 737 x 25	KUR-2923- -N- -	336	471
29 x 29 x 1	737 x 737 x 25	KUR-2929- -N- -	362	503
35 x 29 x 1	889 x 737 x 25	KUR-2935- -N- -	387	547
41 x 29 x 1	1041 x 737 x 25	KUR-2941- -N- -	421	592
47 x 29 x 1	1194 x 737 x 25	KUR-2947- -N- -	471	643
53 x 29 x 1	1346 x 737 x 25	KUR-2953- -N- -	489	661
59 x 29 x 1	1499 x 737 x 25	KUR-2959- -N- -	509	712
65 x 29 x 1	1651 x 737 x 25	KUR-2965- -N- -	553	769
71 x 29 x 1	1803 x 737 x 25	KUR-2971- -N- -	592	834
77 x 29 x 1	1956 x 737 x 25	KUR-2977- -N- -	617	865
83 x 29 x 1	2108 x 737 x 25	KUR-2983- -N- -	643	904
89 x 29 x 1	2261 x 737 x 25	KUR-2989- -N- -	661	941
95 x 29 x 1	2413 x 737 x 25	KUR-2995- -N- -	706	986

Specify the surface type (1, 2). Specify color.

W x D x H (in)	W x D x H (mm)	Code	Laminate (\$)	HPL (\$)
Corner surfaces with cable drop clearance				
<i>Surfaces with 1" (25 mm) clearance on both backs for grommet-free cable management. Curved front (C): radius (Ra) 11 3/4" (300 mm). To be ordered separately: surface supports; refer to page 34.</i>				
<i>23" (585 mm) D on left and on right, 1" (25 mm) clearance at both backs.</i>				
35 x 35 x 1	889 x 889 x 25	KUC-2335- - -N-S-	528	737
41 x 41 x 1	1041 x 1041 x 25	KUC-2341- - -N-S-	592	853
47 x 47 x 1	1194 x 1194 x 25	KUC-2347- - -N-S-	668	955
<i>29" (737 mm) D surfaces on left and on right, 1" (25 mm) clearance at both backs.</i>				
41 x 41 x 1	1041 x 1041 x 25	KUC-2941- - -N-S-	592	853
47 x 47 x 1	1194 x 1194 x 25	KUC-2947- - -N-S-	668	955

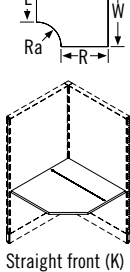

Surface	Straight front (K)
35" (889 mm) D	17" (431 mm)
41" (1041 mm) D	25 1/2" (646 mm)
47" (1194 mm) D	33 7/8" (861 mm)

W x D x H (in)	W x D x H (mm)	Code	Laminate (\$)	HPL (\$)
Standard corner surfaces				
<i>Curved front (C): radius (Ra) 11 3/4" (300 mm). To be ordered separately: surface supports; refer to page 34.</i>				
<i>24" (610 mm) D surfaces on the left and on the right.</i>				
36 x 36 x 1	914 x 914 x 25	KUC-2436- - -S-	560	777
42 x 42 x 1	1067 x 1067 x 25	KUC-2442- - -S-	624	896
48 x 48 x 1	1219 x 1219 x 25	KUC-2448- - -S-	700	1,006
<i>30" (762 mm) D surfaces on the left and on the right.</i>				
42 x 42 x 1	1067 x 1067 x 25	KUC-3042- - -S-	624	896
48 x 48 x 1	1219 x 1219 x 25	KUC-3048- - -S-	700	1,006

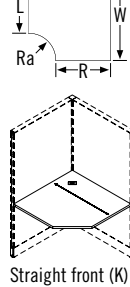

Surface	Straight front (K)
35" (889 mm) D	17" (431 mm)
41" (1041 mm) D	25 1/2" (646 mm)
47" (1194 mm) D	33 7/8" (861 mm)

STANDARD WORK SURFACES

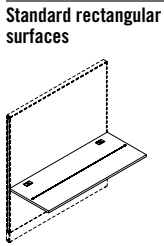

W x D x H (in)	W x D x H (mm)	Code	Laminate (\$)	HPL (\$)
Standard rectangular surfaces				
<i>To be ordered separately: supports and bases, refer to page 34.</i>				
<i>20" (508 mm) D surfaces.</i>				
24 x 20 x 1	610 x 508 x 25	KUR-2024- - -	268	370
30 x 20 x 1	762 x 508 x 25	KUR-2030- - -	286	413
36 x 20 x 1	914 x 508 x 25	KUR-2036- - -	312	445
42 x 20 x 1	1067 x 508 x 25	KUR-2042- - -	344	484
48 x 20 x 1	1219 x 508 x 25	KUR-2048- - -	370	522
54 x 20 x 1	1372 x 508 x 25	KUR-2054- - -	387	560
60 x 20 x 1	1524 x 508 x 25	KUR-2060- - -	421	586
66 x 20 x 1	1676 x 508 x 25	KUR-2066- - -	464	624
72 x 20 x 1	1829 x 508 x 25	KUR-2072- - -	503	680
78 x 20 x 1	1981 x 508 x 25	KUR-2078- - -	522	719
84 x 20 x 1	2134 x 508 x 25	KUR-2084- - -	541	751
90 x 20 x 1	2286 x 508 x 25	KUR-2090- - -	566	788
96 x 20 x 1	2438 x 508 x 25	KUR-2096- - -	578	834
<i>24" (610 mm) D surfaces.</i>				
24 x 24 x 1	610 x 610 x 25	KUR-2424- - -	324	458
30 x 24 x 1	762 x 610 x 25	KUR-2430- - -	356	496
36 x 24 x 1	914 x 610 x 25	KUR-2436- - -	382	535
42 x 24 x 1	1067 x 610 x 25	KUR-2442- - -	413	578
48 x 24 x 1	1219 x 610 x 25	KUR-2448- - -	445	617
54 x 24 x 1	1372 x 610 x 25	KUR-2454- - -	464	668
60 x 24 x 1	1524 x 610 x 25	KUR-2460- - -	496	700
66 x 24 x 1	1676 x 610 x 25	KUR-2466- - -	535	751
72 x 24 x 1	1829 x 610 x 25	KUR-2472- - -	578	814
78 x 24 x 1	1981 x 610 x 25	KUR-2478- - -	592	783
84 x 24 x 1	2134 x 610 x 25	KUR-2484- - -	617	820
90 x 24 x 1	2286 x 610 x 25	KUR-2490- - -	649	865
96 x 24 x 1	2438 x 610 x 25	KUR-2496- - -	712	972
<i>30" (762 mm) D surfaces.</i>				
24 x 30 x 1	610 x 762 x 25	KUR-3024- - -	356	496
30 x 30 x 1	762 x 762 x 25	KUR-3030- - -	382	535
36 x 30 x 1	914 x 762 x 25	KUR-3036- - -	413	578
42 x 30 x 1	1067 x 762 x 25	KUR-3042- - -	445	617
48 x 30 x 1	1219 x 762 x 25	KUR-3048- - -	496	675
54 x 30 x 1	1372 x 762 x 25	KUR-3054- - -	515	694
60 x 30 x 1	1524 x 762 x 25	KUR-3060- - -	535	751
66 x 30 x 1	1676 x 762 x 25	KUR-3066- - -	578	814
72 x 30 x 1	1829 x 762 x 25	KUR-3072- - -	624	878
78 x 30 x 1	1981 x 762 x 25	KUR-3078- - -	649	910
84 x 30 x 1	2134 x 762 x 25	KUR-3084- - -	675	947
90 x 30 x 1	2286 x 762 x 25	KUR-3090- - -	700	986
96 x 30 x 1	2438 x 762 x 25	KUR-3096- - -	745	1,037

Specify surface type (1, 2). Specify with grommets (G) or no grommets (N). Specify color.

Corner surfaces extended on left

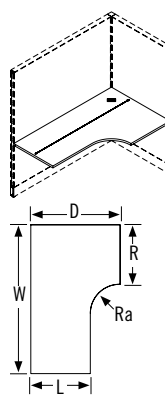

W x D x H (in)	W x D x H (mm)	Code	Laminate (\$)	HPL (\$)
Corner surfaces extended on left				
<i>Curved front (C): radius (Ra) 11 3/4" (300 mm). To be ordered separately: surface supports; refer to page 34.</i>				
<i>24" (610 mm) D surfaces at both ends.</i>				
48 x 36 x 1	1219 x 914 x 25	KUCE-243648-44L- - -	706	986
54 x 36 x 1	1372 x 914 x 25	KUCE-243654-44L- - -	745	1,023
60 x 36 x 1	1524 x 914 x 25	KUCE-243660-44L- - -	788	1,108
66 x 36 x 1	1676 x 914 x 25	KUCE-243666-44L- - -	853	1,195
72 x 36 x 1	1829 x 914 x 25	KUCE-243672-44L- - -	921	1,292
54 x 42 x 1	1372 x 1067 x 25	KUCE-244254-44L- - -	788	1,082
60 x 42 x 1	1524 x 1067 x 25	KUCE-244260-44L- - -	814	1,139
66 x 42 x 1	1676 x 1067 x 25	KUCE-244266-44L- - -	878	1,234
72 x 42 x 1	1829 x 1067 x 25	KUCE-244272-44L- - -	947	1,329
54 x 48 x 1	1372 x 1219 x 25	KUCE-244854-44L- - -	808	1,113
60 x 48 x 1	1524 x 1219 x 25	KUCE-244860-44L- - -	839	1,177
72 x 48 x 1	1829 x 1219 x 25	KUCE-244872-44L- - -	961	1,349
<i>30" (762 mm) D surfaces at both ends.</i>				
54 x 48 x 1	1372 x 1219 x 25	KUCE-304854-55L- - -	808	1,113
60 x 48 x 1	1524 x 1219 x 25	KUCE-304860-55L- - -	839	1,177
72 x 48 x 1	1829 x 1219 x 25	KUCE-304872-55L- - -	961	1,349

Specify surface type (1, 2). Specify with grommets (G) or no grommets (N). Specify color.

Corner surfaces extended on right

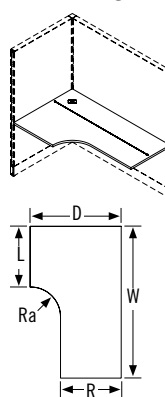

W x D x H (in)	W x D x H (mm)	Code	Laminate (\$)	HPL (\$)
Corner surfaces extended on right				
<i>Curved front (C): radius (Ra) 11 3/4" (300 mm). To be ordered separately: surface supports; refer to page 34.</i>				
<i>24" (610 mm) D surfaces at both ends.</i>				
48 x 36 x 1	1219 x 914 x 25	KUCE-243648-44R- - -	706	986
54 x 36 x 1	1372 x 914 x 25	KUCE-243654-44R- - -	745	1,023
60 x 36 x 1	1524 x 914 x 25	KUCE-243660-44R- - -	788	1,108
66 x 36 x 1	1676 x 914 x 25	KUCE-243666-44R- - -	853	1,195
72 x 36 x 1	1829 x 914 x 25	KUCE-243672-44R- - -	921	1,292
54 x 42 x 1	1372 x 1067 x 25	KUCE-244254-44R- - -	788	1,082
60 x 42 x 1	1524 x 1067 x 25	KUCE-244260-44R- - -	814	1,139
66 x 42 x 1	1676 x 1067 x 25	KUCE-244266-44R- - -	878	1,234
72 x 42 x 1	1829 x 1067 x 25	KUCE-244272-44R- - -	947	1,329
54 x 48 x 1	1372 x 1219 x 25	KUCE-244854-44R- - -	808	1,113
60 x 48 x 1	1524 x 1219 x 25	KUCE-244860-44R- - -	839	1,177
72 x 48 x 1	1829 x 1219 x 25	KUCE-244872-44R- - -	961	1,349
<i>30" (762 mm) D surfaces at both ends.</i>				
54 x 48 x 1	1372 x 1219 x 25	KUCE-304854-55R- - -	808	1,113
60 x 48 x 1	1524 x 1219 x 25	KUCE-304860-55R- - -	839	1,177
72 x 48 x 1	1829 x 1219 x 25	KUCE-304872-55R- - -	961	1,349

Specify surface type (1, 2). Specify with grommets (G) or no grommets (N). Specify color.

W x D x H (in)	W x D x H (mm)	Code	Laminate (\$)	HPL (\$)
Transitional corner surfaces extended on left				
<i>Curved front (C): radius (Ra) 1 1/4" (300 mm). To be ordered separately: surface supports; refer to page 34.</i>				
<i>Surfaces 20" (508 mm) D on left / 24" (610 mm) D on right.</i>				
48 x 36 x 1	1219 x 914 x 25	KUCEA-203648-34L- - -	636	890
54 x 36 x 1	1372 x 914 x 25	KUCEA-203654-34L- - -	675	921
54 x 48 x 1	1372 x 1219 x 25	KUCEA-204854-34L- - -	726	1,006
60 x 48 x 1	1524 x 1219 x 25	KUCEA-204860-34L- - -	751	1,057
72 x 48 x 1	1829 x 1219 x 25	KUCEA-204872-34L- - -	865	1,215
<i>Surfaces 24" (610 mm) D on left / 20" (508 mm) D on right.</i>				
48 x 36 x 1	1219 x 914 x 25	KUCEA-243648-43L- - -	636	890
54 x 36 x 1	1372 x 914 x 25	KUCEA-243654-43L- - -	675	921
54 x 48 x 1	1372 x 1219 x 25	KUCEA-244854-43L- - -	726	1,006
60 x 48 x 1	1524 x 1219 x 25	KUCEA-244860-43L- - -	751	1,057
72 x 48 x 1	1829 x 1219 x 25	KUCEA-244872-43L- - -	865	1,215
<i>Surfaces 24" (610 mm) D on left / 30" (762 mm) D on right.</i>				
48 x 36 x 1	1219 x 914 x 25	KUCEA-243648-45L- - -	706	986
54 x 36 x 1	1372 x 914 x 25	KUCEA-243654-45L- - -	745	1,023
54 x 48 x 1	1372 x 1219 x 25	KUCEA-244854-45L- - -	808	1,113
60 x 48 x 1	1524 x 1219 x 25	KUCEA-244860-45L- - -	839	1,177
72 x 48 x 1	1829 x 1219 x 25	KUCEA-244872-45L- - -	961	1,349
<i>Surfaces 30" (762 mm) D on left / 24" (610 mm) D on right.</i>				
48 x 36 x 1	1219 x 914 x 25	KUCEA-303648-54L- - -	706	986
54 x 36 x 1	1372 x 914 x 25	KUCEA-303654-54L- - -	745	1,023
54 x 48 x 1	1372 x 1219 x 25	KUCEA-304854-54L- - -	808	1,113
60 x 48 x 1	1524 x 1219 x 25	KUCEA-304860-54L- - -	839	1,177
72 x 48 x 1	1829 x 1219 x 25	KUCEA-304872-54L- - -	961	1,349
Specify surface type (1, 2). Specify with grommet (G) or with no grommet (N). Specify color.				

W x D x H (in)	W x D x H (mm)	Code	Laminate (\$)	HPL (\$)
Transitional corner surfaces extended on right				
<i>Curved front (C): radius (Ra) 1 1/4" (300 mm). To be ordered separately: surface supports; refer to page 34.</i>				
<i>Surfaces 20" (508 mm) D on left / 24" (610 mm) D on right.</i>				
48 x 36 x 1	1219 x 914 x 25	KUCEA-203648-34R- - -	636	890
54 x 36 x 1	1372 x 914 x 25	KUCEA-203654-34R- - -	675	921
54 x 48 x 1	1372 x 1219 x 25	KUCEA-204854-34R- - -	726	1,006
60 x 48 x 1	1524 x 1219 x 25	KUCEA-204860-34R- - -	751	1,057
72 x 48 x 1	1829 x 1219 x 25	KUCEA-204872-34R- - -	865	1,215
<i>Surfaces 24" (610 mm) D on left / 20" (508 mm) D on right.</i>				
48 x 36 x 1	1219 x 914 x 25	KUCEA-243648-43R- - -	636	890
54 x 36 x 1	1372 x 914 x 25	KUCEA-243654-43R- - -	675	921
54 x 48 x 1	1372 x 1219 x 25	KUCEA-244854-43R- - -	726	1,006
60 x 48 x 1	1524 x 1219 x 25	KUCEA-244860-43R- - -	751	1,057
72 x 48 x 1	1829 x 1219 x 25	KUCEA-244872-43R- - -	865	1,215
<i>Surfaces 24" (610 mm) D on left / 30" (762 mm) D on right.</i>				
48 x 36 x 1	1219 x 914 x 25	KUCEA-243648-45R- - -	706	986
54 x 36 x 1	1372 x 914 x 25	KUCEA-243654-45R- - -	745	1,023
54 x 48 x 1	1372 x 1219 x 25	KUCEA-244854-45R- - -	808	1,113
60 x 48 x 1	1524 x 1219 x 25	KUCEA-244860-45R- - -	839	1,177
72 x 48 x 1	1829 x 1219 x 25	KUCEA-244872-45R- - -	961	1,349
<i>Surfaces 30" (762 mm) D on left / 24" (610 mm) D on right.</i>				
48 x 36 x 1	1219 x 914 x 25	KUCEA-303648-54R- - -	706	986
54 x 36 x 1	1372 x 914 x 25	KUCEA-303654-54R- - -	745	1,023
54 x 48 x 1	1372 x 1219 x 25	KUCEA-304854-54R- - -	808	1,113
60 x 48 x 1	1524 x 1219 x 25	KUCEA-304860-54R- - -	839	1,177
72 x 48 x 1	1829 x 1219 x 25	KUCEA-304872-54R- - -	961	1,349
Specify surface type (1, 2). Specify with grommets (G) or no grommets (N). Specify color.				

W x D x H (in)	W x D x H (mm)	Code	Laminate (\$)	HPL (\$)
Trapezoidal conference work surfaces				
<i>To be ordered separately: brackets and bases, refer to page 34.</i>				
<i>30" (762 mm) D / 24" (610 mm) W surfaces.</i>				
30 x 48 x 1	762 x 1219 x 25	KUAC-3048- - -	763	986
30 x 54 x 1	762 x 1372 x 25	KUAC-3054- - -	788	1,011
30 x 60 x 1	762 x 1524 x 25	KUAC-3060- - -	814	1,082
30 x 66 x 1	762 x 1676 x 25	KUAC-3066- - -	870	1,151
30 x 72 x 1	762 x 1829 x 25	KUAC-3072- - -	936	1,241
<i>36" (914 mm) D / 30" (762 mm) W surfaces.</i>				
36 x 48 x 1	914 x 1219 x 25	KUAC-3648- - -	846	1,082
36 x 54 x 1	914 x 1372 x 25	KUAC-3654- - -	865	1,108
36 x 60 x 1	914 x 1524 x 25	KUAC-3660- - -	904	1,195
36 x 66 x 1	914 x 1676 x 25	KUAC-3666- - -	955	1,278
36 x 72 x 1	914 x 1829 x 25	KUAC-3672- - -	1,011	1,368
Specify surface type (1, 2). Specify with grommet (G) or with no grommet (N). Specify color.				

W x D x H (in)	W x D x H (mm)	Code	Laminate (\$)	HPL (\$)
Rectangular conference work surfaces				
<i>To be ordered separately: brackets and bases, refer to page 34.</i>				
<i>30" (762 mm) W surfaces.</i>				
30 x 48 x 1	762 x 1219 x 25	KURC-3048- - -	643	820
30 x 54 x 1	762 x 1372 x 25	KURC-3054- - -	655	846
30 x 60 x 1	762 x 1524 x 25	KURC-3060- - -	680	904
30 x 66 x 1	762 x 1676 x 25	KURC-3066- - -	726	967
30 x 72 x 1	762 x 1829 x 25	KURC-3072- - -	777	1,037
<i>36" (914 mm) W surfaces.</i>				
36 x 48 x 1	914 x 1219 x 25	KURC-3648- - -	706	904
36 x 54 x 1	914 x 1372 x 25	KURC-3654- - -	719	921
36 x 60 x 1	914 x 1524 x 25	KURC-3660- - -	751	998
36 x 66 x 1	914 x 1676 x 25	KURC-3666- - -	795	1,069
36 x 72 x 1	914 x 1829 x 25	KURC-3672- - -	846	1,139
Specify surface type (1, 2). Specify with grommets (G) or no grommets (N). Specify color.				

W x D x H (in)	W x D x H (mm)	Code	Laminate (\$)	HPL (\$)
Rectangular transaction countertops				
<i>Recommended only for use on one or two 42 1/4" (1072 mm) H panels. Brackets included. To be ordered separately: top cap KVCP-__, according to configuration. Refer to page 28.</i>				
<i>Installation on one or two panels.</i>				
24 x 14 x 1	610 x 356 x 25	KUT-1424- -N-	344	445
30 x 14 x 1	762 x 356 x 25	KUT-1430- -N-	370	477
36 x 14 x 1	914 x 356 x 25	KUT-1436- -N-	387	509
42 x 14 x 1	1067 x 356 x 25	KUT-1442- -N-	413	547
48 x 14 x 1	1219 x 356 x 25	KUT-1448- -N-	438	586
<i>Installation on two panels only.</i>				
60 x 14 x 1	1524 x 356 x 25	KUT-1460- -N-	522	686
72 x 14 x 1	1829 x 356 x 25	KUT-1472- -N-	808	947
Specify surface type (1, 2). Specify color.				

W x D x H (in)	W x D x H (mm)	Code	Laminate (\$)	HPL (\$)
Corner transaction countertops				
<i>Recommended only for use on 42 1/4" (1072 mm) H panels. Countertop must match the exact width of the two panels. Brackets included. Radius 1 3/4" (350 mm). To be ordered separately: top cap KVCP-__, according to configuration. Refer to page 28.</i>				
<i>14" (356 mm) D surfaces. Installation on two 24" (610 mm) W panels.</i>				
32 x 32 x 1	813 x 813 x 25	KUTC-1424- -N-	649	853
<i>14" (356 mm) D surfaces. Installation on two 30" (762 mm) W panels.</i>				
38 x 38 x 1	965 x 965 x 25	KUTC-1430- -N-	686	998
<i>14" (356 mm) D surfaces. Installation on two 36" (914 mm) W panels.</i>				
44 x 44 x 1	1118 x 1118 x 25	KUTC-1436- -N-	731	1,170
Specify surface type (1, 2). Specify color.				

	W x D x H (in)	W x D x H (mm)	Code	Price (\$)
--	----------------	----------------	------	------------

WORK SURFACE SUPPORTS

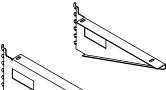
Canilever supports	<i>Is inserted into lateral rails of panels to support the surfaces. Number of supports required may vary according to configuration; refer to page 13. Black. Pack of 2.</i>			
	1 1/2 x 16 3/4 x 7 1/4	38 x 427 x 183	KACB-P-2	147
	3 3/4 x 16 3/4 x 7 1/4	95 x 427 x 183	KACB-S-2	179

Left/right (P)

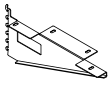

Shared (S), includes a flat bracket

Corner or end brackets	<i>Is inserted into lateral rails of panels to support front or back of surfaces; refer to page 13. Black. Pack of 2 (pair).</i>			
	3 x 4 1/8 x 5	75 x 105 x 126	KAPB-2	57

Flat brackets	<i>Is used to perpendicularly fasten one work surface to another. Black. Pack of 10.</i>			
	5 3/4 x 1 1/2 x 1/4	147 x 38 x 6	KLGC-FLP	114

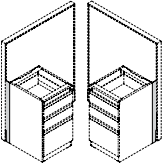
Ped-to-panel attachment fillers	<i>Is used to attach a metal modular pedestal to a panel. May be used with any surface that exceeds pedestal depth by 2 1/8" (54 mm).</i>			
	1 1/8 x 2 3/4 x 27 7/8	30 x 72 x 708	KAPF-L-	191
	1 1/8 x 2 3/4 x 27 7/8	30 x 72 x 708	KAPF-R-	191
	Specify trim color.			

L R

Wall tracks	<i>Is used to fasten panel components to structural walls. 2 tracks are the equivalent of 1 panel. Anchor not included. Pack of 2 wall tracks.</i>			
	Note: Wall tracks may be cut at the installation site.			
	5/8 x 3/4 x 60 3/4	17 x 19 x 1543	KAWT-66-2-	191
	Specify trim color.			

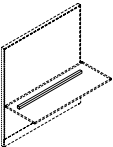
Work surface reinforcement bars	<i>Recommended for certain applications; refer to page 13. Black.</i>			
	<i>For 48" (1219 mm) W surfaces.</i>			
	43 x 1 1/2 x 1 1/2	1092 x 38 x 38	KLGC-BAR43	204
	<i>For 54" et 60" (1372 et 1524 mm) W surfaces.</i>			
	49 x 1 1/2 x 1 1/2	1245 x 38 x 38	KLGC-BAR49	223

WORK SURFACE BASES

Laminate end support panels	<i>Is used to attach a surface to the panel. 2 universal flat brackets allow a left-hand, right-hand or centered installation.</i>			
	1 x 20 x 28	25 x 508 x 711	KAEP-20-	407
	1 x 24 x 28	25 x 610 x 711	KAEP-24-	426
	1 x 30 x 28	25 x 762 x 711	KAEP-30-	477
	Specify color.			

P-metal frames	<i>Is used to attach a surface to the panel. A Silver leg and a cross-bar are included. Compatible with surfaces with a cable drop clearance.</i>			
	2 x 23 3/8 x 28	51 x 600 x 711	KAPL-24-	344
	2 x 29 3/8 x 28	51 x 752 x 711	KAPL-30-	350
	Specify installation on left (L) or right (R). Specify accent color for cross-bar: Silver (S) or Snow (W).			

L R

Intermediate P-metal frames

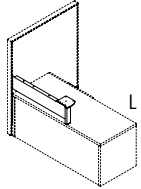
<i>Is used to attach a surface above a low storage module. 1 Silver short leg and a cross-bar are included. Compatible with surfaces with a cable drop clearance.</i>				
	2 x 23 3/8 x 7 3/4	51 x 600 x 198	KAPS-24-	268
	2 x 29 3/8 x 7 3/4	51 x 752 x 198	KAPS-30-	274
	Specify installation on left (L) or right (R). Specify accent color for cross-bar: Silver (S) or Snow (W).			

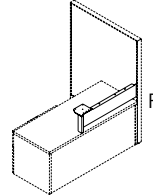
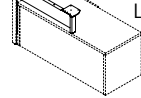

A-frames

<i>2 Silver leg and a cross-bar included. Not compatible with surfaces with a cable drop clearance.</i>				
	2 x 23 3/8 x 28	51 x 600 x 711	KAAL-24-	477
	2 x 29 3/8 x 28	51 x 752 x 711	KAAL-30-	484
	Specify accent color for cross-bar: Silver (S) or Snow (W).			

Intermediate A-frames

<i>Is used to support a surface above a low storage module. 2 Silver short legs and a cross-bar are included. Not compatible with surfaces with a cable drop clearance.</i>				
	2 x 23 3/8 x 7 3/4	51 x 600 x 198	KASL-24-	344
	2 x 29 3/8 x 7 3/4	51 x 752 x 198	KASL-30-	350
	Specify accent color for cross-bar: Silver (S) or Snow (W).			

O-frames

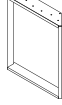
<i>Silver. Not compatible with surfaces with cable drop clearance.</i>				
	2 x 23 1/2 x 28	51 x 597 x 711	KLGC-LP24	680
	2 x 29 1/2 x 28	51 x 747 x 711	KLGC-LP30	719

I-post, individual

<i>Silver. Square.</i>				
	2 1/2 x 2 1/2 x 28	64 x 64 x 711	KLGC-QTL1	229

I-post for conference work surface

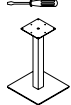
<i>Silver. Square.</i>				
	17 x 17 x 28	432 x 432 x 711	KLGC-SB17	870

STORAGE UNITS

METAL STORAGE UNITS

CODIFICATION

EXAMPLE: KMPML-1522-1-P53-FOS

Series	Type of product	Front option	Furniture dimension	Drawer option	Metal finishes	
					Trims	Laminate front
K	MSZ Suspended shelf MSH Overhead hutch MPF Modular pedestal MPM Mobile pedestal MPS Personal mobile storage unit	L Laminate		3 Box/box/file 2 File/file 1 Box/file L Concealed box/ access on left R Concealed box/ access on right F Concealed box/file	P53 Snow P44 Metallic Silver P04 Charcoal	



LAMINATE STORAGE UNITS

EXAMPLE: KLSRB-1236-1-L-SNO-FOS

The first finish will be applied to frame.
The second finish will be applied to front.

CODIFICATION

Series	Type of product	Option	Furniture dimension	Shelf width	Orientation	Laminate finishes	
K	LSO Overhead hutch with flipper door LCS Open center-mounted hutch LCO Center-mounted hutch with sliding door LSR Suspended storage unit with drop-down door LPB Personal storage tower LPW Wardrobe LSP Storage unit with lateral opening compartment LLS Low storage module with drawer and open bookcase	S Shared T Upper shelf B Lower shelf		12 12" (305 mm) 24 24" (610 mm)	L Left R Right	A Rest of product B Front	

	W x D x H (in)	W x D x H (mm)	Code	Price (\$)
METAL STORAGE FURNITURE				
Modular pedestals				
<i>Enables support of a surface with a depth greater than that of the pedestal. Lock. Suspension bar included with each file drawer. Note: Laminate fronts must be assembled at installation site.</i>				
Metal frame and fronts.				
<i>Box/box/file.</i>				
	15 1/4 x 21 7/8 x 27 3/8	386 x 556 x 701	KMPF-1522-3-	834
Box/box/file	15 1/4 x 17 7/8 x 27 3/8	386 x 454 x 701	KMPF-1518-3-	834
<i>File/file.</i>				
	15 1/4 x 21 7/8 x 27 3/8	386 x 556 x 701	KMPF-1522-2-	745
File/file	15 1/4 x 17 7/8 x 27 3/8	386 x 454 x 701	KMPF-1518-2-	745
Metal frame and laminate fronts.				
<i>Box/box/file.</i>				
	15 1/4 x 21 7/8 x 27 3/8	386 x 556 x 701	KMPFL-1522-3-	1,057
	15 1/4 x 17 7/8 x 27 3/8	386 x 454 x 701	KMPFL-1518-3-	1,057
<i>File/file.</i>				
	15 1/4 x 21 7/8 x 27 3/8	386 x 556 x 701	KMPFL-1522-2-	947
	15 1/4 x 17 3/4 x 27 3/8	386 x 454 x 701	KMPFL-1518-2-	947
Specify the metal finish color. For model with laminate fronts, specify finish.				

	W x D x H (in)	W x D x H (mm)	Code	Price (\$)
Mobile pedestal				
<i>Lock. Suspension bar included with each file drawer. Note: Only box/file can accept a cushion (KMCU-15_ _). Laminate fronts must be assembled at installation site.</i>				
Metal frame and fronts.				
<i>Box/box/file.</i>				
	15 1/4 x 21 7/8 x 26 7/8	386 x 556 x 683	KMPM-1522-3-	961
Box/box/file	15 1/4 x 18 7/8 x 26 7/8	386 x 479 x 683	KMPM-1519-3-	961

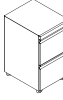
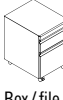
	W x D x H (in)	W x D x H (mm)	Code	Price (\$)
<i>File/file.</i>				
	15 1/4 x 21 7/8 x 26 7/8	386 x 556 x 683	KMPM-1522-2-	853
File/file	15 1/4 x 18 7/8 x 26 7/8	386 x 479 x 683	KMPM-1519-2-	853
<i>Box/file.</i>				
	15 1/4 x 21 7/8 x 21 1/8	386 x 556 x 536	KMPM-1522-1-	757
Box/file	15 1/4 x 18 7/8 x 21 1/8	386 x 479 x 536	KMPM-1519-1-	757
Metal frame and laminate fronts.				
<i>Box/box/file.</i>				
	15 1/4 x 21 7/8 x 26 7/8	386 x 556 x 683	KMPML-1522-3-	1,184
	15 1/4 x 18 7/8 x 26 7/8	386 x 479 x 683	KMPML-1519-3-	1,184
<i>File/file.</i>				
	15 1/4 x 21 7/8 x 26 7/8	386 x 556 x 683	KMPML-1522-2-	1,057
	15 1/4 x 18 7/8 x 26 7/8	386 x 479 x 683	KMPML-1519-2-	1,057
<i>Box/file.</i>				
	15 1/4 x 21 7/8 x 21 1/8	386 x 556 x 536	KMPML-1522-1-	941
	15 1/4 x 18 7/8 x 21 1/8	386 x 479 x 536	KMPML-1519-1-	941
Specify the metal finish color. For model with laminate fronts, specify finish.				

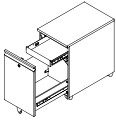
	W x D x H (in)	W x D x H (mm)	Code	Price (\$)
Personal mobile storage units				
<i>Lock. Concealed box drawer. Note: Can accept a cushion (KMCU-1219). Laminate fronts must be assembled at the installation site.</i>				
Metal frame and front.				
	12 x 18 7/8 x 20	305 x 479 x 510	KMPS-1219-_-	936
Left (L)				
Metal frame and laminate front.				
	12 x 18 7/8 x 20	305 x 479 x 510	KMPSL-1219-_-	1,049
Specify access side: left (L), right (R) or file drawer (F). Specify the metal finish color. For model with laminate front, specify finish.				

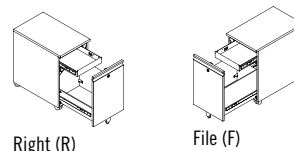

	W x D x H (in)	W x D x H (mm)	Code	Price (\$)
Cushions	<i>Is installed on a mobile pedestal or a personal mobile storage unit using self-adhesive strips. Prices shown apply to all Grade 1 and 2 United Chair® fabrics. For other United Chair® grades, add: Grade 3: 15%, Grade 4: 20%, Grade 5: 25% and Grade 6: 30%.</i>			
	15 1/4 x 21 7/8 x 7/8	387 x 556 x 22	KMCU-1522-___	401
	15 1/4 x 18 7/8 x 7/8	387 x 479 x 22	KMCU-1519-___	395
	12 x 18 7/8 x 7/8	305 x 479 x 22	KMCU-1219-___	387
	Specify cushion upholstery.			

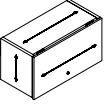
LAMINATE STORAGE FURNITURE				
Overhead hutches with flipper door	<i>Lock. Laminate frame and flipper door. Hardware included.</i>			
	24 x 14 1/2 x 16 1/8	610 x 366 x 408	KLSO-1624-___	1,033
	30 x 14 1/2 x 16 1/8	762 x 366 x 408	KLSO-1630-___	1,080
	36 x 14 1/2 x 16 1/8	914 x 366 x 408	KLSO-1636-___	1,127
	42 x 14 1/2 x 16 1/8	1067 x 366 x 408	KLSO-1642-___	1,192
	48 x 14 1/2 x 16 1/8	1219 x 366 x 408	KLSO-1648-___	1,249
	Specify laminate finishes A/B.			

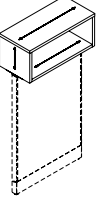
Open center-mounted hutches	<i>Open space(s) with laminate back. Attaches to top of panel. Hardware included. One tone only. To be ordered separately: top cap KVCP-___, according to configuration. Refer to page 28.</i>			
	12 7/8" (328 mm) H.			
	<i>Installation on 1 or 2 panels.</i>			
	24 x 14 x 12 7/8	610 x 356 x 328	KLCS-1224-___	910
	30 x 14 x 12 7/8	762 x 356 x 328	KLCS-1230-___	921
	36 x 14 x 12 7/8	914 x 356 x 328	KLCS-1236-___	955
	42 x 14 x 12 7/8	1067 x 356 x 328	KLCS-1242-___	980
	48 x 14 x 12 7/8	1219 x 356 x 328	KLCS-1248-___	1,144
	<i>Installation on 2 panels only.</i>			
	60 x 14 x 12 7/8	1524 x 356 x 328	KLCS-1260-___	1,201
	72 x 14 x 12 7/8	1829 x 356 x 328	KLCS-1272-___	1,278
24" to 42" (610 to 1067 mm)				

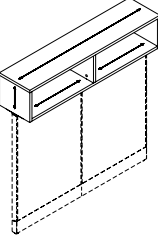
Open center-mounted hutches (cont'd)	15" (381 mm) H.			
	<i>Installation on 1 or 2 panels.</i>			
	24 x 14 x 15	610 x 356 x 381	KLCS-1524-___	916
	30 x 14 x 15	762 x 356 x 381	KLCS-1530-___	941
	36 x 14 x 15	914 x 356 x 381	KLCS-1536-___	972
	42 x 14 x 15	1067 x 356 x 381	KLCS-1542-___	998
	48 x 14 x 15	1219 x 356 x 381	KLCS-1548-___	1,164
	<i>Installation on 2 panels only.</i>			
	60 x 14 x 15	1524 x 356 x 381	KLCS-1560-___	1,227
	72 x 14 x 15	1829 x 356 x 381	KLCS-1572-___	1,303
48" to 72" (1219 to 1829 mm)				

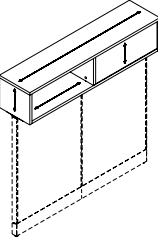
Shared open center-mounted storage units	<i>Open space with laminate back. Attaches to top of panel. Hardware included. One tone only. To be ordered separately: top cap KVCP-___, according to configuration. Refer to page 28.</i>			
	12 7/8" (328 mm) H.			
	<i>Installation on 1 or 2 panels.</i>			
	42 x 14 x 12 7/8	1067 x 356 x 328	KLCSS-1242-___	1,190
	48 x 14 x 12 7/8	1219 x 356 x 328	KLCSS-1248-___	1,234
	<i>Installation on 2 panels only.</i>			
	60 x 14 x 12 7/8	1524 x 356 x 328	KLCSS-1260-___	1,252
	72 x 14 x 12 7/8	1829 x 356 x 328	KLCSS-1272-___	1,335
	15" (381 mm) H.			
	<i>Installation on 1 or 2 panels.</i>			
	42 x 14 x 15	1067 x 356 x 381	KLCSS-1542-___	1,210
	48 x 14 x 15	1219 x 356 x 381	KLCSS-1548-___	1,252
	<i>Installation on 2 panels only.</i>			
	60 x 14 x 15	1524 x 356 x 381	KLCSS-1560-___	1,272
	72 x 14 x 15	1829 x 356 x 381	KLCSS-1572-___	1,354
	Specify side for open storage unit: left (L) or right (R). Specify laminate finish.			

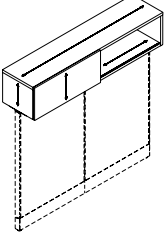
	W x D x H (in)	W x D x H (mm)	Code	Price (\$)
Center-mounted hutches with sliding door	<i>Open spaces with sliding door and laminate back. Attaches to top of panel. Hardware included. To be ordered separately: top cap KVCP-___, according to configuration. Refer to page 28.</i>			
	12 7/8" (328 mm) H.			
	<i>Installation on 1 or 2 panels.</i>			
	36 x 14 3/4 x 12 7/8	914 x 375 x 328	KLCO-1236-___	1,494
	42 x 14 3/4 x 12 7/8	1067 x 375 x 328	KLCO-1242-___	1,520
	48 x 14 3/4 x 12 7/8	1219 x 375 x 328	KLCO-1248-___	1,693
	<i>Installation on 2 panels only.</i>			
	60 x 14 3/4 x 12 7/8	1524 x 375 x 328	KLCO-1260-___	1,761
	72 x 14 3/4 x 12 7/8	1829 x 375 x 328	KLCO-1272-___	1,864
	15" (381 mm) H.			
	<i>Installation on 1 or 2 panels.</i>			
	36 x 14 3/4 x 15	914 x 375 x 381	KLCO-1536-___	1,514
	42 x 14 3/4 x 15	1067 x 375 x 381	KLCO-1542-___	1,533
	48 x 14 3/4 x 15	1219 x 375 x 381	KLCO-1548-___	1,718
	<i>Installation on 2 panels only.</i>			
	60 x 14 3/4 x 15	1524 x 375 x 381	KLCO-1560-___	1,787
	72 x 14 3/4 x 15	1829 x 375 x 381	KLCO-1572-___	1,896
	Specify laminate finishes A/B.			

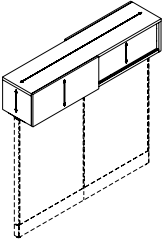
Shared center-mounted hutches with sliding doors	<i>Open spaces with sliding doors and laminate back on both sides. Attaches to top of panel. Hardware included. To be ordered separately: top cap KVCP-___, according to configuration. Refer to page 28.</i>			
	12 7/8" (328 mm) H.			
	<i>Installation on 1 or 2 panels.</i>			
	42 x 14 3/4 x 12 7/8	1067 x 375 x 328	KLCOS-1242-___	2,309
	48 x 14 3/4 x 12 7/8	1219 x 375 x 328	KLCOS-1248-___	2,397
	<i>Installation on 2 panels only.</i>			
	60 x 14 3/4 x 12 7/8	1524 x 375 x 328	KLCOS-1260-___	2,404
	72 x 14 3/4 x 12 7/8	1829 x 375 x 328	KLCOS-1272-___	2,564
L	Specify side for open storage unit: left (L) or right (R). Specify laminate finishes A/B.			

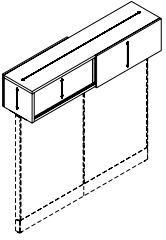
Shared center-mounted hutches with sliding doors	<i>Open spaces with sliding doors and laminate back on both sides. Attaches to top of panel. Hardware included. To be ordered separately: top cap KVCP-___, according to configuration. Refer to page 28.</i>			
	15" (381 mm) H.			
	<i>Installation on 1 or 2 panels.</i>			
	42 x 14 3/4 x 15	1067 x 375 x 381	KLCOS-1542-___	2,346
	48 x 14 3/4 x 15	1219 x 375 x 381	KLCOS-1548-___	2,436
	<i>Installation on 2 panels only.</i>			
	60 x 14 3/4 x 15	1524 x 375 x 381	KLCOS-1560-___	2,449
	72 x 14 3/4 x 15	1829 x 375 x 381	KLCOS-1572-___	2,607
R	Specify side for open storage unit: left (L) or right (R). Specify laminate finishes A/B.			

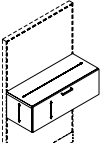
	W x D x H (in)	W x D x H (mm)	Code	Laminate (\$)	HPL (\$)
Suspended storage units with drop-down door	<i>Assisted-opening door. Lock. Open space with back. Storage units 42" (1067 mm) W or greater have a central divider.</i>				
	24 x 14½ x 12¾	610 x 368 x 314	KLSR-1224-	1,451	
	30 x 14½ x 12¾	762 x 368 x 314	KLSR-1230-	1,502	
	36 x 14½ x 12¾	914 x 368 x 314	KLSR-1236-	1,552	
	42 x 14½ x 12¾	1067 x 368 x 314	KLSR-1242-	1,608	
	48 x 14½ x 12¾	1219 x 368 x 314	KLSR-1248-	1,659	
	60 x 14½ x 12¾	1524 x 368 x 314	KLSR-1260-	1,761	
	Specify laminate finishes A/B.				

Suspended storage units with drop-down door and upper shelf *Assisted-opening door. Lock. Open space with back. Flat brackets for fastening to a work surface are included. Storage units 42" (1067 mm) W or greater have a central divider.*

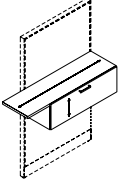
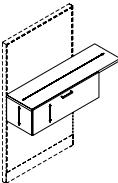
	W x D x H (in)	W x D x H (mm)	Code	Laminate (\$)	HPL (\$)
<i>12" (305 mm) W shelf.</i>					
	36 x 14½ x 12¾	914 x 368 x 314	KLSRT-1224-12-	1,488	1,634
	42 x 14½ x 12¾	1067 x 368 x 314	KLSRT-1230-12-	1,545	1,698
	48 x 14½ x 12¾	1219 x 368 x 314	KLSRT-1236-12-	1,596	1,756
	54 x 14½ x 12¾	1372 x 368 x 314	KLSRT-1242-12-	1,654	1,819
	60 x 14½ x 12¾	1524 x 368 x 314	KLSRT-1248-12-	1,705	1,876
	72 x 14½ x 12¾	1829 x 368 x 314	KLSRT-1260-12-	1,813	1,998
<i>24" (610 mm) W shelf.</i>					
	48 x 14½ x 12¾	1219 x 368 x 314	KLSRT-1224-24-	1,540	1,685
	54 x 14½ x 12¾	1372 x 368 x 314	KLSRT-1230-24-	1,596	1,749
	60 x 14½ x 12¾	1524 x 368 x 314	KLSRT-1236-24-	1,647	1,806
	66 x 14½ x 12¾	1676 x 368 x 314	KLSRT-1242-24-	1,705	1,870
	72 x 14½ x 12¾	1829 x 368 x 314	KLSRT-1248-24-	1,756	1,927
	84 x 14½ x 12¾	2134 x 368 x 314	KLSRT-1260-24-	1,864	2,049
	Specify shelf side: left (L) or right (R). Specify surface type (1,2). Specify laminate/HPL finishes A/B.				

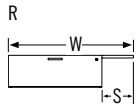

Suspended storage units with drop-down door and lower shelf *Assisted-opening door. Lock. Open space with back. Shelf may require a reinforcement or support. Storage units 42" (1067 mm) W or greater have a central divider.*

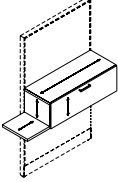
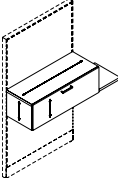
	W x D x H (in)	W x D x H (mm)	Code	Laminate (\$)	HPL (\$)
<i>12" (305 mm) W shelf.</i>					
	36 x 14½ x 12¾	914 x 368 x 314	KLSRB-1224-12-	1,488	
	42 x 14½ x 12¾	1067 x 368 x 314	KLSRB-1230-12-	1,545	
	48 x 14½ x 12¾	1219 x 368 x 314	KLSRB-1236-12-	1,596	
	54 x 14½ x 12¾	1372 x 368 x 314	KLSRB-1242-12-	1,654	
	60 x 14½ x 12¾	1524 x 368 x 314	KLSRB-1248-12-	1,705	
	72 x 14½ x 12¾	1829 x 368 x 314	KLSRB-1260-12-	1,813	
<i>24" (610 mm) W shelf.</i>					
	48 x 14½ x 12¾	1219 x 368 x 314	KLSRB-1224-24-	1,540	
	54 x 14½ x 12¾	1372 x 368 x 314	KLSRB-1230-24-	1,596	
	60 x 14½ x 12¾	1524 x 368 x 314	KLSRB-1236-24-	1,647	
	66 x 14½ x 12¾	1676 x 368 x 314	KLSRB-1242-24-	1,705	
	72 x 14½ x 12¾	1829 x 368 x 314	KLSRB-1248-24-	1,756	
	84 x 14½ x 12¾	2134 x 368 x 314	KLSRB-1260-24-	1,864	
	Specify shelf side: left (L) or right (R). Specify laminate finishes A/B.				

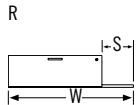

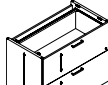

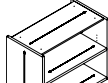
	W x D x H (in)	W x D x H (mm)	Code	Price (\$)
Modular lateral files	<i>Is used to support a surface whose depth is equal to or greater than that of the file. Lock. Suspension bar included with each file drawer.</i>			
	29½ x 20 x 28	748 x 508 x 711	KLFF-2030-	1,787
	35¾ x 20 x 28	898 x 508 x 711	KLFF-2036-	1,826
	Specify laminate finishes A/B.			

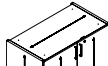
	W x D x H (in)	W x D x H (mm)	Code	Price (\$)
Modular bookcases	<i>Is used to support a surface whose depth is equal to or greater than that of the bookcase. Lock. Adjustable shelf.</i>			
	29½ x 19¼ x 28	748 x 488 x 711	KLBE-2030-	1,190
	35¾ x 19¼ x 28	898 x 488 x 711	KLBE-2036-	1,285
	Specify the laminate finish.			

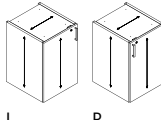
	W x D x H (in)	W x D x H (mm)	Code	Price (\$)
Modular bookcases with doors	<i>Is used to support a surface whose depth is equal to or greater than that of the bookcase. Lock. Adjustable shelf. Lock.</i>			
	29½ x 20 x 28	748 x 508 x 711	KLBI-2030-	1,412
	35¾ x 20 x 28	898 x 508 x 711	KLBI-2036-	1,463
	Specify laminate finishes A/B.			

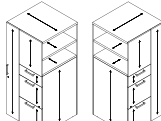
	W x D x H (in)	W x D x H (mm)	Code	Price (\$)
Modular bookcases with door	<i>Is used to support a surface whose depth is equal to or greater than that of the bookcase. Lock. Adjustable shelf. Lock.</i>			
	18 x 20 x 28	457 x 508 x 711	KLBF-2018-	1,144
	Specify door opening: hinges on left (L) or hinges on right (R). Specify laminate finishes A/B.			

	W x D x H (in)	W x D x H (mm)	Code	Price (\$)
Personal storage towers with bookcase / wardrobe	<i>1 box drawer and 2 file drawers. Suspension bars. Pencil tray. Clothes hanger bar and fixed shelf. Adjustable shelf on bookcase side on models 54" (1372 mm) and 66¾" (1686 mm) H.</i>			
	<i>Wardrobe on left, bookcase on right.</i>			
	24 x 24 x 47⅞	610 x 610 x 1215	KLPB-242448-L-	2,888
	24 x 24 x 54	610 x 610 x 1372	KLPB-242454-L-	3,052
	24 x 24 x 66¾	610 x 610 x 1686	KLPB-242466-L-	3,219
	<i>Wardrobe on right, bookcase on left.</i>			
	24 x 24 x 47⅞	610 x 610 x 1215	KLPB-242448-R-	2,888
	24 x 24 x 54	610 x 610 x 1372	KLPB-242454-R-	3,052
	24 x 24 x 66¾	610 x 610 x 1686	KLPB-242466-R-	3,219
	Specify laminate finishes A/B.			

	W x D x H (in)	W x D x H (mm)	Code	Price (\$)
Wardrobes	<i>Clothes hanger bar. Lock. Models 48" (1219 mm) H and greater have a fixed shelf.</i>			
	<i>12" (305 mm) W.</i>			
	12 x 24 x 41⅞	305 x 610 x 1058	KLPW-241242-	1,991
	12 x 24 x 47⅞	305 x 610 x 1215	KLPW-241248-	2,049
	12 x 24 x 54	305 x 610 x 1372	KLPW-241254-	2,100
	12 x 24 x 66¾	305 x 610 x 1686	KLPW-241266-	2,151
	<i>15" (381 mm) W.</i>			
	15 x 24 x 41⅞	381 x 610 x 1058	KLPW-241542-	2,091
	15 x 24 x 47⅞	381 x 610 x 1215	KLPW-241548-	2,157
	15 x 24 x 54	381 x 610 x 1372	KLPW-241554-	2,213
	15 x 24 x 66¾	381 x 610 x 1686	KLPW-241566-	2,264
	Specify door opening: hinges on left (L) or hinges on right (R). Specify laminate finishes A/B.			

	W x D x H (in)	W x D x H (mm)	Code	Price (\$)
Storage units with lateral opening compartment	<i>Compartment with door and an adjustable shelf. Lock. Model 30" (762 mm) in depth includes a wardrobe space with a clothes hook. Models 54" (1372 mm) H have an additional fixed shelf.</i>			
	<i>12" (305 mm) W.</i>			
	12 x 24 x 41 ⁵ / ₈	305 x 610 x 1058	KLSP-122442-_-_-	2,595
	12 x 24 x 47 ⁷ / ₈	305 x 610 x 1215	KLSP-122448-_-_-	2,741
	12 x 24 x 54	305 x 610 x 1372	KLSP-122454-_-_-	2,894
	12 x 30 x 41 ⁵ / ₈	305 x 762 x 1058	KLSP-123042-_-_-	2,766
	12 x 30 x 47 ⁷ / ₈	305 x 762 x 1215	KLSP-123048-_-_-	2,843
	12 x 30 x 54	305 x 762 x 1372	KLSP-123054-_-_-	2,926
	<i>15" (381 mm) W.</i>			
	15 x 24 x 41 ⁵ / ₈	381 x 610 x 1058	KLSP-152442-_-_-	2,741
15 x 24 x 47 ⁷ / ₈	381 x 610 x 1215	KLSP-152448-_-_-	2,824	
15 x 24 x 54	381 x 610 x 1372	KLSP-152454-_-_-	2,906	
15 x 30 x 41 ⁵ / ₈	381 x 762 x 1058	KLSP-153042-_-_-	2,837	
15 x 30 x 47 ⁷ / ₈	381 x 762 x 1215	KLSP-153048-_-_-	2,914	
15 x 30 x 54	381 x 762 x 1372	KLSP-153054-_-_-	2,990	
	Specify access side: left (L) or right (R). Specify laminate finishes A/B.			
Shared low storage units with drawers	<i>1 box drawer and 1 file drawer per side. Suspension bars. Pencil trays. Locks. Accommodates one or two cushions (KLCU-__20); refer to page 38.</i>			
	47 ¹ / ₄ x 20 x 20 ¹ / ₄	1200 x 508 x 513	KLSS-204820-_-_-	3,129
	59 x 20 x 20 ¹ / ₄	1500 x 508 x 513	KLSS-206020-_-_-	3,301
	70 ¹ / ₈ x 20 x 20 ¹ / ₄	1800 x 508 x 513	KLSS-207220-_-_-	3,465
		Specify laminate finishes A/B.		

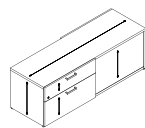
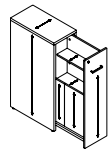
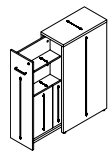

	W x D x H (in)	W x D x H (mm)	Code	Price (\$)
Low storage modules with drawers and open bookcase	<i>1 box drawer and 1 file drawer. Suspension bar. Pencil tray. Lock. Open bookcase with back. Adjustable shelf. Can accept one or two cushions (KLCU-__20); refer to page 38.</i>			
	47 ¹ / ₄ x 20 x 20 ¹ / ₄	1200 x 508 x 513	KLLS-204820-_-_-	2,760
	59 x 20 x 20 ¹ / ₄	1500 x 508 x 513	KLLS-206020-_-_-	2,812
	70 ¹ / ₈ x 20 x 20 ¹ / ₄	1800 x 508 x 513	KLLS-207220-_-_-	2,945
	Specify open side of bookcase: left (L) or right (R). Specify laminate finishes A/B.			

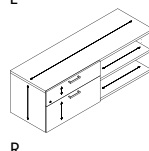
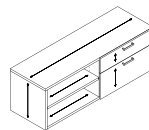

	W x D x H (in)	W x D x H (mm)	Code	Price (\$)
Cushions for laminate low storage modules	<i>Is installed on a low storage module using self-adhesive strips. Prices shown apply to all Grade 1 and 2 United Chair® fabrics. For other United Chair® grades, add: Grade 3: 15%, Grade 4: 20%, Grade 5: 25% and Grade 6: 30%.</i>			
	23 ³ / ₈ x 19 ¹ / ₄ x 7 ¹ / ₈	600 x 490 x 22	KLCU-2420-_-_-	407
	29 ¹ / ₂ x 19 ¹ / ₄ x 7 ¹ / ₈	750 x 490 x 22	KLCU-3020-_-_-	426
	35 ³ / ₈ x 19 ¹ / ₄ x 7 ¹ / ₈	900 x 490 x 22	KLCU-3620-_-_-	445
	Specify cushion upholstery.			



ACCESSORIES

	W x D x H (in)	W x D x H (mm)	Code	Price (\$)
Accessory rails	<i>Is inserted into the lateral rails on a panel.</i>			
	23 ⁵ / ₈ x 1/2 x 1 1/2	593 x 11 x 38	KKAR-24-_-_-	242
	29 ³ / ₈ x 1/2 x 1 1/2	745 x 11 x 38	KKAR-30-_-_-	254
	35 ³ / ₈ x 1/2 x 1 1/2	897 x 11 x 38	KKAR-36-_-_-	261
	41 ³ / ₈ x 1/2 x 1 1/2	1050 x 11 x 38	KKAR-42-_-_-	268
	47 ³ / ₈ x 1/2 x 1 1/2	1202 x 11 x 38	KKAR-48-_-_-	280
59 ³ / ₈ x 1/2 x 1 1/2	1507 x 11 x 38	KKAR-60-_-_-	286	
	Specify trim color.			

	W x D x H (in)	W x D x H (mm)	Code	Price (\$)
All-purpose trays	<i>Metal. Compatible with all Lacasse accessory rails. Pack of 2.</i>			
	12 x 3 ³ / ₄ x 1 1/8	305 x 96 x 30	KKAT-RAST2-_-_-	210
	Specify trim color.			

	W x D x H (in)	W x D x H (mm)	Code	Price (\$)
Vertical paper trays	<i>Metal. Compatible with all Lacasse accessory rails. Pack of 2.</i>			
	11 ³ / ₄ x 2 ⁵ / ₈ x 8	300 x 68 x 203	KKAT-RVPT11-_-_-	331
	Specify trim color.			

	W x D x H (in)	W x D x H (mm)	Code	Price (\$)
Horizontal paper trays	<i>Metal. Compatible with all Lacasse accessory rails. Pack of 2.</i>			
	<i>Letter format.</i>			
	12 x 9 ⁷ / ₈ x 2	305 x 251 x 50	KKAT-RPT11-_-_-	261
	<i>Legal format.</i>			
14 x 9 ⁷ / ₈ x 2	375 x 251 x 50	KKAT-RPT14-_-_-	280	
	Specify trim color.			

	W x D x H (in)	W x D x H (mm)	Code	Price (\$)
Tackboards	<i>Is inserted into the lateral rails on a panel. Not required for fabric acoustical panels. Prices shown apply to all Grade 1 and 2 United Chair® fabrics (except vinyl and leather). For other United Chair® grades, add: Grade 3: 15%, Grade 4: 20%, Grade 5: 25% and Grade 6: 30%.</i>			
	<i>6¹/₈" (157 mm) H.</i>			
	23 ⁵ / ₈ x 3/8 x 6 ¹ / ₈	593 x 10 x 157	KKATB-0624-_-_-	375
	29 ³ / ₈ x 3/8 x 6 ¹ / ₈	745 x 10 x 157	KKATB-0630-_-_-	395
	35 ³ / ₈ x 3/8 x 6 ¹ / ₈	897 x 10 x 157	KKATB-0636-_-_-	413
	41 ³ / ₈ x 3/8 x 6 ¹ / ₈	1050 x 10 x 157	KKATB-0642-_-_-	433
	47 ³ / ₈ x 3/8 x 6 ¹ / ₈	1202 x 10 x 157	KKATB-0648-_-_-	452
	<i>12³/₈" (314 mm) H.</i>			
	23 ³ / ₈ x 3/8 x 12 ³ / ₈	593 x 10 x 314	KKATB-1224-_-_-	401
	29 ³ / ₈ x 3/8 x 12 ³ / ₈	745 x 10 x 314	KKATB-1230-_-_-	426
	35 ³ / ₈ x 3/8 x 12 ³ / ₈	897 x 10 x 314	KKATB-1236-_-_-	452
	41 ³ / ₈ x 3/8 x 12 ³ / ₈	1050 x 10 x 314	KKATB-1242-_-_-	477
	47 ³ / ₈ x 3/8 x 12 ³ / ₈	1202 x 10 x 314	KKATB-1248-_-_-	503
		Specify panel upholstery.		

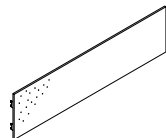

	W x D x H (in)	W x D x H (mm)	Code	Price (\$)
Whiteboards	<i>Folded metal. Is inserted into a panel's lateral rails. High-gloss white finish for dry-erase markers. Magnetic.</i>			
	<i>12³/₈" (314 mm) H.</i>			
	23 ⁵ / ₈ x 3/8 x 12 ³ / ₈	593 x 10 x 314	KKAMB-1224-_-_-	229
	29 ³ / ₈ x 3/8 x 12 ³ / ₈	745 x 10 x 314	KKAMB-1230-_-_-	242
	35 ³ / ₈ x 3/8 x 12 ³ / ₈	897 x 10 x 314	KKAMB-1236-_-_-	274
	41 ³ / ₈ x 3/8 x 12 ³ / ₈	1050 x 10 x 314	KKAMB-1242-_-_-	286
	47 ³ / ₈ x 3/8 x 12 ³ / ₈	1202 x 10 x 314	KKAMB-1248-_-_-	305
	59 ³ / ₈ x 3/8 x 12 ³ / ₈	1507 x 10 x 314	KKAMB-1260-_-_-	528
	<i>24³/₄" (628 mm) H.</i>			
	23 ⁵ / ₈ x 3/8 x 24 ³ / ₄	593 x 10 x 628	KKAMB-2424-_-_-	319
	29 ³ / ₈ x 3/8 x 24 ³ / ₄	745 x 10 x 628	KKAMB-2430-_-_-	401
	35 ³ / ₈ x 3/8 x 24 ³ / ₄	897 x 10 x 628	KKAMB-2436-_-_-	426
	41 ³ / ₈ x 3/8 x 24 ³ / ₄	1050 x 10 x 628	KKAMB-2442-_-_-	458
	47 ³ / ₈ x 3/8 x 24 ³ / ₄	1202 x 10 x 628	KKAMB-2448-_-_-	515
59 ³ / ₈ x 3/8 x 24 ³ / ₄	1507 x 10 x 628	KKAMB-2460-_-_-	870	

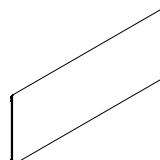

	W x D x H (in)	W x D x H (mm)	Code	Price (\$)
Shelves	<i>Is inserted into a panel's side rails. Brackets included.</i>			
	24 x 7 x 1	610 x 177 x 25	KKAS-24-_-_-	312
	30 x 7 x 1	762 x 177 x 25	KKAS-30-_-_-	324
	36 x 7 x 1	914 x 177 x 25	KKAS-36-_-_-	331
	Specify trim color. Specify the laminate finish.			



	W x D x H (in)	W x D x H (mm)	Code	Price (\$)
Modesty panels	<i>Provides a visual barrier beneath a work surface. Support has a Silver finish. Is fastened beneath a surface with a clearance equal to or greater than the width of the modesty panel.</i>			
	30 x 3/8 x 12	761 x 16 x 305	KKML-1230-_-_-	477
	36 x 3/8 x 12	913 x 16 x 305	KKML-1236-_-_-	528
	42 x 3/8 x 12	1065 x 16 x 305	KKML-1242-_-_-	610
	Specify the laminate finish.			

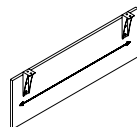







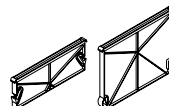

	W x D x H (in)	W x D x H (mm)	Code	Price (\$)
Trays for metal pedestals	<i>Made of black plastic. Is placed along the sides of a box drawer. Compatible only with 15¹/₄" (386 mm) W pedestals.</i>			
	<i>Model with 4 compartments.</i>			
	12 ³ / ₄ x 5 ¹ / ₂ x 1	325 x 142 x 25	KKPHU-6-_-_-	96
	<i>Model with 2 compartments.</i>			
12 ¹ / ₈ x 3 x 1	327 x 76 x 25	KKPHU-3-_-_-	45	



	W x D x H (in)	W x D x H (mm)	Code	Price (\$)
Dividers for metal pedestals	<i>Made of black plastic. Is inserted between the sides of a box or file drawer. Compatible only with 15¹/₄" (386 mm) W pedestals. Can also be used as a compressor.</i>			
	<i>For box drawer.</i>			
	12 ³ / ₈ x 3/4 x 4 ³ / ₈	320 x 18 x 112	KKDIV-5-_-_-	71
	<i>For file drawer.</i>			
12 ³ / ₈ x 3/4 x 9 ³ / ₈	320 x 18 x 238	KKDIV-10-_-_-	82	



	W x D x H (in)	W x D x H (mm)	Code	Price (\$)
 Sliding tray <i>Molded plastic on wood. Height adjustment 3", 3 1/2", 4" (76, 89, 102 mm). Locks in extended position. Black.</i>	28 3/8 x 15 x 3 1/2	721 x 381 x 89	KLGC-SKD27	356
 Pole-mounted support for flat screen <i>Is installed on the corner or side of a desk. Double-extension arm to support a screen. Sit-to-stand capability. Metal silver accent.</i>	20 3/4 x 6 1/2 x 17 3/4	527 x 167 x 450	KLGC-SUPECPLS	1,057
 Pole-mounted double support for flat screen <i>Is installed on the corner or side of a desk. 2 double-extension arms allow rotating and front-back movement of screens. Sit-to-stand capability. Silver accent.</i>	48 x 24 x 6 1/2	1200 x 610 x 167	KLGC-SUP2ECPLS	1,673
 Storage drawer <i>Made of black plastic.</i>	19 5/8 x 16 7/8 x 2 5/8	500 x 430 x 68	KKDR-20	286
 Suspended personal storage modules – 5 3/8" H <i>Is installed beneath a work surface. 5 3/8" H model can fit inside the 15 3/8" H model to create a two-compartment storage unit.</i>	9 7/8 x 15 x 5 3/8	245 x 383 x 136	KKASC-5-	357
 Suspended personal storage modules – 5 3/8" H <i>Metal, with laminate shelf.</i>	9 7/8 x 15 x 5 3/8	245 x 383 x 136	KKASCL-5-	433
Specify trim color. For model with laminate shelf, specify the laminate finish.				
 Hanging personal storage compartments – 15 3/8" H <i>Is installed beneath a work surface. 5 3/8" H model can fit inside the 15 3/8" H model to create a two-compartment storage unit.</i>	9 3/4 x 15 x 15 3/8	248 x 383 x 390	KKASC-15-	461
 Hanging personal storage compartments – 15 3/8" H <i>Metal, with laminate shelf.</i>	9 3/4 x 15 x 15 3/8	248 x 383 x 390	KKASCL-15-	536
Specify trim color. For model with laminate shelf, specify the laminate finish.				

PARADIGM Panel System > Price Book > USA > February 2025

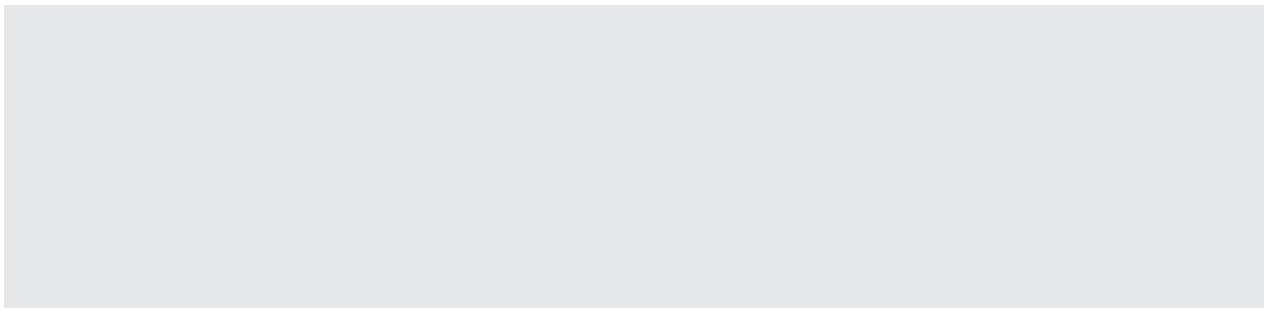
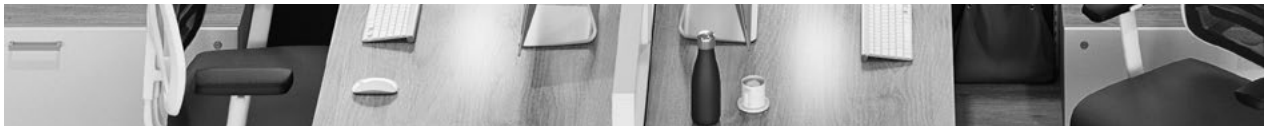

Office Furniture Solutions

Founded in 1956, Groupe Lacasse is a North American leader in the design, manufacture and service of a broad range of high-quality furniture products for all types of work environments. We have the experience, expertise and capability to deliver incomparable design, exceptional quality, optimum service and outstanding value in Office Furniture Solutions.



1-888-522-2773
www.groupelacasse.com